



REVISED 5/2/2025

REQUEST FOR QUALIFICATIONS

Runway 8R/26L Rehabilitation Consulting

REQUEST NUMBER: 2518

DUE DATE: June 5, 2025

DUE TIME: 2:00 pm (local)

Contents

INTRODUCTION 3

SOLICITATION AND PROJECT SCHEDULE 3

VOLUNTARY ON-SITE CONFERENCE 3

WORK SCOPE 4

Existing Condition Assessment and Reporting 4

Development of Preliminary Design Plans, Phasing Strategy, and Cost Estimates..... 4

Operational Impact Mitigation and Phasing Considerations 4

Preliminary Design and Financial Planning Support..... 5

Final Design, Specifications, and Bidding Support..... 5

Construction Administration and Closeout Services..... 5

Grant Support and Funding Assistance..... 5

CONTRACTURAL EXPECTATIONS 5

REQUESTS FOR INFORMATION..... 6

SUBMISSION FORMAT AND EVALUATION CRITERIA 6

Template Evaluation Matric..... 7

REQUEST FOR PROPOSAL SUBMISSION 8

AIRPORT SECURITY 8

TERMS AND CONDITIONS 10

MICHIGAN FREEDOM OF INFORMATION ACT 12

EVALUATION, STATUS UPDATES/AWARD NOTIFICATION 12

FEDERAL PROVISIONS 14

EXHIBITS 27

Exhibit A – 2023 PCI 27

Exhibit B – GRR ASR Locations 28

Exhibit C – Pavement Section Locations with PCRs 29

INTRODUCTION

The Gerald R. Ford International Airport Authority (GFIAA) is requesting statements of qualifications from interested firms to provide multi-year Preliminary Design, Design Engineering, and Construction Administration services for the Rehabilitation of Runway 8R-26L.

The Gerald R. Ford International Airport is the second busiest airport in Michigan, serving business and leisure travelers with nonstop and connecting flights on eight airlines. The Ford Airport is managed and operated by the Gerald R. Ford International Airport Authority.

GFIAA is seeking a consulting firm for Preliminary Design, Design, and Construction Administration services for the full length, including the intersection of Runway 17-35, rehabilitation of Runway 8R-26L through a 2-part public Qualifications Based Selection (QBS) process which includes an initial qualifications evaluation followed by short list interviews and fee negotiation with the selected firm. This 2-part selection process articulates the GFIAA’s goals and provides openness and consistency so that all qualified firms receive fair consideration.

SOLICITATION AND PROJECT SCHEDULE

ACTIVITY	DATE
RFQ Issue Date	May 2, 2025
Voluntary On-Site Conference	May 20, 2025
Question Deadline	May 22, 2025
Submission Due Date	June 5, 2025 at 2 pm
Contract Start Date	July 2025

GFIAA reserves the right to modify the deadline set forth in the above table in its sole discretion. Any such modifications will be stated in an addendum.

VOLUNTARY ON-SITE CONFERENCE

CONFERENCE DETAILS	
Conference Date	May 20, 2025
Conference Time (local)	9 am
Conference Location	International Room 1st floor of the airport terminal building,

	5500 44th St. SE, Grand Rapids, MI 49512
--	--

A voluntary pre-submission conference is scheduled for this request. Equal opportunity will be provided for all Respondents to ask questions.

Attendees should arrive a minimum of five (5) minutes before the scheduled date and time. Attendees will not be allowed to sign in after the conference has commenced. If a firm representative does not sign in prior to the scheduled pre-submission conference, their firm will not be considered.

Attendees requiring special services are asked to provide their requirements to the GFIAA at least forty-eight (48) hours in advance to allow for accommodations.

An voluntary on-site tour will be offered to all attendees following the conclusion of the meeting.

WORK SCOPE

The Scope of Services outlined below, as may be modified through negotiation and/or by written addendum issued by the Airport Authority, will be incorporated into the final Agreement with the selected Consultant. The selected Consultant will be expected to provide a full range of professional engineering, pre-design, design, construction, and grant support services related to the rehabilitation of Runway 8R/26L. These services will be delivered in accordance with all applicable Federal Aviation Administration (FAA), state, and local regulations, guidelines, and best practices.

Existing Condition Assessment and Reporting

- Conduct a comprehensive field inspection and evaluation of the existing pavement structure, drainage infrastructure, and other related components of Runway 8R/26L.
- Perform non-destructive testing and core sampling as needed to evaluate pavement condition and subgrade integrity.
- Document findings in a detailed Existing Conditions Report, including photographic evidence, engineering assessments, and recommendations for rehabilitation or reconstruction strategies.
- Identify any deficiencies affecting operational safety or long-term serviceability.

Development of Preliminary Design Plans, Phasing Strategy, and Cost Estimates

- Prepare preliminary engineering plans showing proposed improvement concepts for Runway 8R/26L.
- Develop a phased implementation strategy designed to minimize operational disruptions and maintain compliance with FAA and airport operational requirements.
- Provide conceptual-level cost estimates, broken down by phase, to support budgeting and planning.
- Coordinate with airport staff to prioritize improvements based on operational needs and funding availability.

Operational Impact Mitigation and Phasing Considerations

- Design a project phasing approach that ensures minimal to no disruption to daily airport operations, with particular attention to maintaining airfield access and aircraft movement.
- Collaborate with Airport Operations, FAA Air Traffic Control, and other stakeholders to develop and vet phased construction scenarios.
- Include temporary traffic control plans, safety management strategies, and night or off-peak construction options as appropriate.

Preliminary Design and Financial Planning Support

- Advance selected alternatives through preliminary design, incorporating stakeholder feedback and technical considerations.
- Analyze and recommend the most cost-effective and technically feasible rehabilitation, or reconstruction, method, including eligibility for FAA Airport Improvement Program (AIP) or other funding.
- Assist in refining the project's financial plan, including lifecycle cost analysis and prioritization of eligible and ineligible items under FAA funding criteria.
- Facilitate coordination meetings with FAA and airport staff to define final project scope.

Final Design, Specifications, and Bidding Support

- Develop full construction documents, including detailed design drawings, technical specifications, bid item descriptions, and engineer's estimates.
- Ensure all plans meet FAA standards, including AC 150/5370 series and other applicable design circulars.
- Assist with bid phase services, including responding to contractor inquiries, issuing addenda, attending pre-bid meetings, and evaluating bids for compliance and responsiveness.

Construction Administration and Closeout Services

- Provide construction phase services including full-time or part-time resident inspection, materials testing, submittal review, and quality assurance monitoring.
- Oversee contract administration functions, such as pay application reviews, change order evaluations, and schedule tracking.
- Maintain communication with contractors, airport staff, and FAA throughout the construction period to ensure adherence to scope, budget, and schedule.
- Prepare and deliver complete as-built drawings and final project documentation in both hard copy and digital formats as required by the Airport Authority and FAA.

Grant Support and Funding Assistance

- Identify eligible state and federal funding sources applicable to the project, including FAA AIP grants, state aviation grants, and other potential opportunities.
- Prepare or support preparation of grant applications, project justification narratives, and supplemental documentation required for funding submittals.
- Assist the Airport Authority in meeting all grant-related reporting and compliance requirements throughout the project lifecycle.
- Coordinate with FAA on reimbursement requests, project closeout procedures, and documentation audits.

CONTRACTURAL EXPECTATIONS

GFIAA anticipates utilizing the Michigan Department of Transportation Office of Aeronautics (MDOT-AERO) standard consultant contract as a basis for the consultant contract resulting from this selection. Contract documents will be outlined in part 2 of this selection process which will be issued to short listed firms. Federal regulations related to the use of federal funding will be incorporated into the contract.

Consultants are encouraged to include Disadvantaged Business Enterprise (DBE) firms in their submittal including those certified via the Michigan Department of Transportation Michigan Unified Certification Program (MUCP).

REQUESTS FOR INFORMATION

Questions regarding this solicitation are to be submitted in writing to purchasing@grr.org prior to 2 p.m. on May 22, 2025.

GFIAA reserves the right to publish and respond to an inquiry, respond directly to the inquirer without publishing or not respond to the inquiry at its sole discretion. Unless otherwise indicated, all questions will be compiled into one document and answers will be issued as a Questions & Answers document within 4 days after the question deadline.

It is the firm's responsibility to become familiar with and fully informed regarding the terms, conditions, and specifications of this solicitation. Lack of understanding or misinterpretation of any portions of this solicitation shall not be cause for withdrawal after opening or for subsequent protest of award.

Addendums will only be published by the GFIAA Purchasing Department and available for review at www.grr.org.

SUBMISSION FORMAT AND EVALUATION CRITERIA

Submissions should include and will be evaluated on the elements in weighted categories out of 100 points outlined below:

PART 1 – Solicitation Phase – 100 Points

Executive Summary and Business Organization (0 points) – Two (2) pages maximum

Summarize the Respondent's strong points and how experience, particularly with similar responsibilities, will benefit the stakeholders. State the full name and address of the organization and, if applicable, the branch office, consultants, or other subordinate elements that will provide or assist in providing the service. **Include phone number(s), email address(s) and Respondent's website address.**

Firm Experience and Qualifications (25 points) – One (1) page maximum

State the full name and address of the organization and, if applicable, the branch office, consultants, or other subordinate elements that will provide or assist in providing the service. Include phone number(s), email address(s) and Respondent's website address.

Understanding of Federal Provisions (10 points) – Two (2) pages maximum

The Respondent's understanding and experience with federal provisions, including compliance with FAA regulations, environmental requirements, and other applicable federal laws, will be a key consideration in the evaluation process. Additionally, Respondents must demonstrate their ability to effectively communicate and coordinate with the local FAA Airport District Office (ADO) to ensure alignment with federal guidelines and local airport needs.

Approach and Methodology (25 points) – Twelve (12) pages maximum

State in succinct terms the Respondent's understanding of the major issues of this request. Describe specifically the Respondent's intended process and responsibilities. Identify important steps that will be taken

to meet the GFIAA’s expectations and identify deliverables. Respondent should also show experience with pavement reconstruction if rehabilitation is not the determined method of improvement.

Key Personnel and Project Team (30 points) – No Page Limit

Provide a chart with the staff you are committing to the project. Show lines of authority and communication, and provide a brief role description, responsibilities and availability for each person as they relate to the project. The respondent shall demonstrate both technical knowledge and project management abilities. In addition to representing team members’ experience, the team’s approach to defining and managing projects, including coordination with the Airport through project closeout, should be demonstrated. Attach resumes of all personnel in GSA SF-330 Part 1 format.

References (10 points) – One (1) page maximum

Provide a minimum of three (3) relevant references, preferably for projects of similar scope and complexity. Include the names of the projects, location, completion date, project cost, and specific challenges; identify project team members and references for each project including telephone numbers and email addresses.

PART 2 – Interview Phase (Shortlisted Firms Only) – 25 Points

Firm Interview (25 points)

Shortlisted firms will be invited to participate in an interview as part of the final selection process. The interview will provide an opportunity for the selection committee to further evaluate each firm’s project understanding, team qualifications, and approach, as well as to ask clarifying questions related to the submitted proposal.

Template Evaluation Matrix

125 Points

Evaluation Criteria	Maximum Points	Score	Comments
Executive Summary	0	N/A	Not Scored
Firm Experience and Qualifications	25		
Understanding of Federal Provisions	10		
Approach and Methodology	25		
Key Personnel and Project Team	30		
References	10		
Interview (Shortlist Firms Only)	25		
Total –	100		

REQUEST FOR PROPOSAL SUBMISSION

Responses may be delivered physically or electronically. To be considered, complete submissions must be received prior to the due date and time specified (local time).

- Hard copy responses can be mailed or otherwise delivered to the address below.

Submission address:

Attn: AJ Nye, Procurement Specialist

Gerald R Ford International Airport Authority

5500 44th St SE

Grand Rapids, MI 49512

- Electronic responses can be securely uploaded as a single pdf document to:

<https://www.dropbox.com/request/f4hoTpMdnwXu1nEGWhl>

Electronic submissions shall be named with a form or portion of the firm's name as part of the document name.

The firm certifies the response submitted has not been made or prepared in collusion with any other respondent and the prices, terms or conditions thereof have not been communicated by or on behalf of the respondent to any other respondent prior to the official opening of this request. This certification may be treated for all purposes as if it were a sworn statement made under oath, subject to the penalties for perjury. Moreover, it is made subject to the provisions of 18 U.S.C. Section 1001, relating to the making of false statements.

Submissions may be withdrawn by written request only if the request is received on or before the opening date and time.

Submissions not meeting these criteria may be deemed non-responsive.

GFIAA is not liable for any costs incurred by any prospective firm prior to the awarding of a contract, including any costs incurred in addressing this solicitation.

AIRPORT SECURITY

It is essential that during the performance of this contract that airport security be maintained and that operations under this agreement conform to Airport security requirements.

Airport-Issued Identification Badges -

Identification badges are issued by the Airport Police Department to provide unescorted access to authorized employees performing job duties within the airport. Contractors assigned to this account must be badged to provide services within the Secure Area. GRFIAA will not provide escort. The Contractor assumes responsibility for the conduct of all personnel working on airport property. All personnel within the Secured Area must display an airport-issued identification badge or be escorted by personnel with a badge who has been granted escort privileges. Identification badges must be worn on an individual's outermost garment and above the waist at all times.

The Airport encourages all Contractor personnel to be badged. **An unbadged person is to be under escort at all times.** This will be strictly enforced.

Badges are the property of the Airport and must be returned promptly upon fulfilment of this agreement, an individual's termination or at the request of the GRFIAA. Failure to return badges may result in the Contractor being declared nonresponsive and ineligible for future Airport contracts.

Pre-Badging Requirements for General Contractor -

Contractor should coordinate badge requirements with the Airport Project Manager. DO NOT WAIT UNTIL THE LAST MINUTE. The following documents are required before the Contractor begin the badging process for themselves, their subcontractors or their employees:

1. Project Letter from Contractor – Letter must include the Project Name with Start Date and estimated End Date, PLUS a list of all Subcontractors (if any).
2. Authorized Signer Letter(s) – Contractors/subcontractors will designate one or more individuals to be Authorized Signers for badge enrollments. The Authorized Signer letter must be on company letterhead. An Authorized Signer must obtain an airport badge prior to attending signatory training which is administered by the Airport Security Coordinator. The badging process is outlined below.

Badging Process –

The badging process requires two visits to the Airport Police office for each applicant.

1. Badge Application and Background Checks

The process is initiated with the Authorized Signatory. They will be enrolling the applicant in the airport's SAFE Signatory Portal. Once enrolled and submitted, each applicant must make an initial appointment with the airport badging office. (www.grrbadging.as.me)

As outlined in the appointment information, each individual is required to provide 2 pieces of acceptable ID, as well as provide a completed GRR Fingerprint Application. Information about acceptable IDs and the GRR Fingerprint Application can be found on the badging services page: <http://www.grr.org/badging-services.php>

The airport will perform two background checks on the applicant:

- a. A security threat assessment (STA) is a name verification background check conducted by the Transportation Security Administration (TSA).
- b. A criminal history records check (CHRC) is a fingerprint-based background check to determine if personnel have been convicted of a felony within the last ten (10) years. Background check results can take anywhere from two days to two weeks to be completed.

The Contractor's Authorized Signatory will be notified once the background checks have been completed and approved. The Authorized Signatory will notify the individual and have them schedule their assigned appointment for Badge Training and Issuance.

2. Training and Badge Issuance

The applicant will make an appointment at www.grrbadging.as.me for their assigned training and badge issuance. Training may include the following depending on which privileges the Authorized Signatory assigned during enrollment:

- a. SIDA training
- b. Non-movement driver's training

Each training takes approximately 45 minutes to complete. Once completed and passed, the individual will receive their ID.

Training/Badging must be completed within 30 days from date of approval. Applicants who fail to complete badging within the allotted time will be assessed a resubmission fee.

3. Authorized Signatory Training (IF APPLICABLE)

If an individual will be designated as an Authorized Signatory for their company, they will need to schedule an appointment for Authorized Signatory Training with the Airport Security Coordinator. This is typically handled through communication with the original Authorized Signatory and can only be completed after they have received their badge.

All initial badging fees will be at no cost to the Contractor. If an ID badge is lost, stolen, or otherwise unaccounted for immediate notify Airport Communications at 616.233.6055. The ID badge replacement fee is \$50.00. The badge holder is responsible for the ID badge replacement fee.

TERMS AND CONDITIONS

GFIAA reserves the right to require that its standard terms and conditions apply to any actual order placed in response to a firm's submission. No attempt to modify GFIAA's Standard Terms and Conditions shall be binding, absent agreement on such modification in writing and signed by GFIAA.

No payment shall be made to the Respondent for any extra material or services, or of any greater amount of money than stipulated to be paid in the contract, unless changes in or additions to the contract requiring additional outlay by the Respondent shall first have been expressly authorized and ordered in writing by contract amendment or otherwise furnished by the GFIAA.

The intent of these specifications is to solicit a properly designed and all-inclusive response. Any requirements not in the specifications, but which are needed for such a response, are to be included in the submission.

The Gerald R Ford International Airport Authority, in accordance with the provisions of Title VI of the Civil Rights Act of 1964 (78 Stat. 252, 42 USC §§ 2000d to 2000d-4) and the Regulations, hereby notifies all bidders or offerors that it will

affirmatively ensure that for any contract entered into pursuant to this advertisement, [select businesses, or disadvantaged business enterprises or airport concession disadvantaged business enterprises] will be afforded full and fair opportunity to submit bids in response to this invitation and no businesses will be discriminated against on the grounds of race, color, national origin (including limited English proficiency), creed, sex (including sexual orientation and gender identity), age, or disability in consideration for an award.

The Respondent shall not discriminate against an employee or applicant for employment with respect to hire, tenure, terms, conditions or privileges of employment, or a matter directly or indirectly related to employment, because of race, color, religion, national origin, age, sex, height, weight, marital status, or disability that is unrelated to the individual's ability to perform the duties of a particular job or position.

The Respondent shall observe and comply with all applicable federal, state, and local laws, ordinances, rules and regulations at all times during the completion of any contract with the GFIAA.

The terms of this request shall be interpreted, construed and enforced pursuant to the laws of the State of Michigan, and the Parties irrevocably consent to the jurisdiction of the federal and state courts presiding in Michigan.

The GFIAA is tax-exempt and a regional airport authority organized under 2015 P.A. 95, being MCL 259.137 et. seq.

Vendor Representation and Warranty Regarding Federal Excluded Parties List: The Respondent acknowledges that the GFIAA may be receiving funds from or through the Federal Government; such funds may not be used to pay any Respondent on the Federal Excluded Parties List (EPLS). The Respondent represents and warrants to the GFIAA that it is not on the Federal EPLS. If the Respondent is in non-compliance at any time during execution or term of this agreement (including any extensions thereof), the Respondent shall be in breach and the GFIAA shall be entitled to all remedies available to it at law or equity, specifically including but not limited to recovery of all moneys paid to the Respondent, all consequential damages (including the loss of grant funding or the requirement that grant funding be returned), and attorney fees (including the costs of in-house counsel) sustained as a result of the Respondent's non-compliance with this warranty and representation.

Pursuant to the Michigan Iran Economic Sanctions Act, 2012 P.A. 517, by submitting a bid, proposal or response, Respondent certifies, under civil penalty for false certification, that it is fully eligible to do so under law and that it is not an "Iran linked business," as that term is defined in the Act.

Insurance requirements are posted on the Documents and Forms page of the GFIAA website within the Purchasing Terms and Conditions document.

Termination For Cause: Should the firm fail to perform the Work as required by and in accordance with the schedule or time requirements, or otherwise violate any of the terms set forth in the Solicitation Request, it shall constitute breach of the Contract. Other than in force majeure situations, Respondent shall have five (5) calendar days to cure a breach of the Contract (the "Cure Period") following issuance of GFIAA written notice. Failure to cure a breach of the Contract within said Cure Period shall allow the GFIAA to, without further notice to the Respondent, declare the Contract terminated and proceed with the replacement of the Respondent and the GFIAA shall be entitled to all remedies available to it at law or in equity including a claim against any required payment/performance bonds.

Termination Without Cause: Notwithstanding any other provision, at any time and without cause, GFIAA shall have

the right, in its sole discretion, to terminate the contract by giving sixty (60) days written notice.

Although it is the intent to contract with one provider, the GFIAA reserves the right to contract with alternate sources if the Respondent is unable or unwilling to service its obligation, or it is deemed by GFIAA to be in its best interest to use alternate sources.

Assignment: Neither party shall assign or delegate any of its rights or obligations under this Agreement without the prior written consent of the other party.

Respondent warrants that they are an authorized provider of products or services of his/her submission.

MICHIGAN FREEDOM OF INFORMATION ACT

Information submitted in this solicitation is subject to the Michigan Freedom of Information Act and may not be held in confidence after the Respondent's submission is opened. A submission will be available for review after the project has been awarded.

GFIAA cannot assure that all of the information submitted as part of or peripheral to the Respondent's submission will be kept confidential. Any Respondent submission language designated as confidential is considered automatically invalid and void. GFIAA is subject to the Michigan Freedom of Information Act, which prohibits it from concealing information on or associated with responses, successful or unsuccessful, once they are opened.

EVALUATION, STATUS UPDATES/AWARD NOTIFICATION

The Authority reserves the right to request additional information it may deem necessary after the submissions are received.

As part of the evaluation process, Respondents may be requested to make an oral presentation, at the Respondent's expense, to an evaluation committee. Key staff to be assigned to this project must participate in this presentation unless otherwise waived by the Authority. The presentation may be followed by a question-and-answer session.

The Authority reserves the right at its discretion to waive irregularities of this solicitation process.

In the event of extension errors, the unit price shall prevail and the Respondent's total offer will be corrected accordingly. In the event of addition errors, the extended totals will prevail and the Respondent's total will be corrected accordingly. Respondent must check their submission where applicable. Failure to do so will be at the Respondent's risk. Submissions having erasures or corrections must be initialed in ink by the Respondent. Respondents are cautioned to recheck their submissions for possible errors.

The Respondent shall not be allowed to take advantage of error, omissions or discrepancies in the specifications.

The Authority, at its sole discretion, reserves the right to award to the Respondent whose response is deemed most advantageous to the Authority. The Authority, at its sole discretion, shall select the most responsive and responsible Respondent and evaluate all responses based on the requirements and criterion set forth in this solicitation while reserving the right to weigh specifications and other factors in the award. The Authority reserves the right to reject any and all submissions as a result of this solicitation.

The Authority reserves the right to award by line item when applicable and to accept or reject any or all parts of a submission.

Accelerated discounts should be so stated at the time of submission. If quick-pay discounts are offered, The Authority reserves the right to include that discount as part of the award criterion. Prices must, however, be based upon payment in thirty (30) days after receipt, inspection, and acceptance. In all cases, quick-pay discounts will be calculated from the date of the invoice or the date of acceptance, whichever is later.

Award notifications are posted on the Authority website. It is the Respondent's responsibility to monitor the website for status updates.

FEDERAL PROVISIONS

NOTICE OF REQUIREMENT FOR AFFIRMATIVE ACTION TO ENSURE EQUAL EMPLOYMENT OPPORTUNITY

1. The Offeror's or Bidder's attention is called to the "Equal Opportunity Clause" and the "Standard Federal Equal Employment Opportunity Construction Contract Specifications" set forth herein.
2. The goals and timetables for minority and female participation, expressed in percentage terms for the Contractor's aggregate workforce in each trade on all construction work in the covered area, are as follows:

Timetables

Goals for minority participation for each trade: **[Sponsor must insert established goal]**

Goals for female participation in each trade: 6.9%

These goals are applicable to all of the Contractor's construction work (whether or not it is Federal or federally assisted) performed in the covered area. If the Contractor performs construction work in a geographical area located outside of the covered area, it shall apply the goals established for such geographical area where the work is actually performed. With regard to this second area, the Contractor also is subject to the goals for both its federally involved and nonfederally involved construction.

The Contractor's compliance with the Executive Order and the regulations in 41 CFR Part 60-4 shall be based on its implementation of the Equal Opportunity Clause, specific affirmative action obligations required by the specifications set forth in 41 CFR 60-4.3(a) and its efforts to meet the goals. The hours of minority and female employment and training must be substantially uniform throughout the length of the contract, and in each trade, and the Contractor shall make a good faith effort to employ minorities and women evenly on each of its projects. The transfer of minority or female employees or trainees from Contractor to Contractor or from project to project for the sole purpose of meeting the Contractor's goals shall be a violation of the contract, the Executive Order and the regulations in 41 CFR Part 60-4. Compliance with the goals will be measured against the total work hours performed.

3. The Contractor shall provide written notification to the Director of the Office of Federal Contract Compliance Programs (OFCCP) within 10 working days of award of any construction subcontract in excess of \$10,000 at any tier for construction work under the contract resulting from this solicitation. The notification shall list the name, address, and telephone number of the subcontractor; employer identification number of the subcontractor; estimated dollar amount of the subcontract; estimated starting and completion dates of the subcontract; and the geographical area in which the subcontract is to be performed.

4. As used in this notice and in the contract resulting from this solicitation, the "covered area" is **[Sponsor must insert state, county, and city]**.

FAA BUY AMERICAN PREFERENCE

The Contractor certifies that its bid/offer is in compliance with 49 USC § 50101, BABA and other related Made in America Laws,¹ U.S. statutes, guidance, and FAA policies, which provide that Federal funds may not be obligated unless all iron, steel and manufactured goods used in AIP funded projects are produced in the United States, unless the Federal Aviation Administration has issued a waiver for the product; the product is listed as an Excepted Article, Material Or Supply in Federal Acquisition Regulation subpart 25.108; or is included in the FAA Nationwide Buy American Waivers Issued list.

The bidder or offeror must complete and submit the certification of compliance with FAA's Buy American Preference, BABA and Made in America laws included herein with their bid or offer. The Airport Sponsor/Owner will reject as nonresponsive any bid or offer that does not include a completed certification of compliance with FAA's Buy American Preference and BABA.

The bidder or offeror certifies that all constructions materials, defined to mean an article, material, or supply other than an item of primarily iron or steel; a manufactured product; cement and cementitious materials; aggregates such as stone, sand, or gravel; or aggregate binding agents or additives that are or consist primarily of: non-ferrous metals; plastic and polymer-based products (including polyvinylchloride, composite building materials, and polymers used in fiber optic cables); glass (including optic glass); lumber; or drywall used in the project are manufactured in the U.S.

¹ Per Executive Order 14005 "Made in America Laws" means all statutes, regulations, rules, and Executive Orders relating to federal financial assistance awards or federal procurement, including those that refer to "Buy America" or "Buy American," that require, or provide a preference for, the purchase or acquisition of goods, products, or materials produced in the United States, including iron, steel, and manufactured products offered in the United States.

Title VI Solicitation Notice:

The (**Name of Sponsor**), in accordance with the provisions of Title VI of the Civil Rights Act of 1964 (78 Stat. 252, 42 USC §§ 2000d to 2000d-4) and the Regulations, hereby notifies all bidders or offerors that it will affirmatively ensure that for any contract entered into pursuant to this advertisement, [select businesses, or disadvantaged business enterprises or airport concession disadvantaged business enterprises] will be afforded full and fair opportunity to submit bids in response to this invitation and no businesses will be discriminated against on the grounds of race, color, national origin (including limited English proficiency), creed, sex (including sexual orientation and gender identity), age, or disability in consideration for an award.

Title VI List of Pertinent Nondiscrimination Acts and Authorities

During the performance of this contract, the Contractor, for itself, its assignees, and successors in interest (hereinafter referred to as the “Contractor”) agrees to comply with the following non-discrimination statutes and authorities; including but not limited to:

- Title VI of the Civil Rights Act of 1964 (42 USC § 2000d *et seq.*, 78 stat. 252) (prohibits discrimination on the basis of race, color, national origin);
- 49 CFR part 21 (Non-discrimination in Federally-Assisted programs of the Department of Transportation—Effectuation of Title VI of the Civil Rights Act of 1964);
- The Uniform Relocation Assistance and Real Property Acquisition Policies Act of 1970, (42 USC § 4601) (prohibits unfair treatment of persons displaced or whose property has been acquired because of Federal or Federal-aid programs and projects);
- Section 504 of the Rehabilitation Act of 1973 (29 USC § 794 *et seq.*), as amended (prohibits discrimination on the basis of disability); and 49 CFR part 27 (Nondiscrimination on the Basis of Disability in Programs or Activities Receiving Federal Financial Assistance);
- The Age Discrimination Act of 1975, as amended (42 USC § 6101 *et seq.*) (prohibits discrimination on the basis of age);
- Airport and Airway Improvement Act of 1982 (49 USC § 47123), as amended (prohibits discrimination based on race, creed, color, national origin, or sex);
- The Civil Rights Restoration Act of 1987 (PL 100-259) (broadened the scope, coverage and applicability of Title VI of the Civil Rights Act of 1964, the Age Discrimination Act of 1975 and Section 504 of the Rehabilitation Act of 1973, by expanding the definition of the terms “programs or activities” to include all of the programs or activities of the Federal-aid recipients, sub-recipients and contractors, whether such programs or activities are Federally funded or not);
- Titles II and III of the Americans with Disabilities Act of 1990 (42 USC § 12101, *et seq*) (prohibit discrimination on the basis of disability in the operation of public entities, public and private transportation systems, places of public accommodation, and certain testing entities) as implemented by U.S. Department of Transportation regulations at 49 CFR parts 37 and 38;
- The Federal Aviation Administration’s Nondiscrimination statute (49 USC § 47123) (prohibits discrimination on the basis of race, color, national origin, and sex);
- Executive Order 12898, Federal Actions to Address Environmental Justice in Minority Populations and Low-Income Populations (ensures nondiscrimination against minority populations by discouraging programs, policies, and activities with disproportionately high and adverse human health or environmental effects on minority and low-income populations);
- Executive Order 13166, Improving Access to Services for Persons with Limited English Proficiency, and resulting agency guidance, national origin discrimination includes discrimination because of limited English proficiency (LEP). To ensure compliance with Title VI, you must take reasonable steps to ensure that LEP persons have meaningful access to your programs [70 Fed. Reg. 74087 (2005)];

- Title IX of the Education Amendments of 1972, as amended, which prohibits you from discriminating because of sex in education programs or activities (20 USC § 1681, et seq).

DAVIS-BACON REQUIREMENTS

1. Minimum Wages.

(i) All laborers and mechanics employed or working upon the site of the work will be paid unconditionally and not less often than once a week, and without subsequent deduction or rebate on any account (except such payroll deductions as are permitted by the Secretary of Labor under the Copeland Act (29 CFR Part 3)), the full amount of wages and bona fide fringe benefits (or cash equivalent thereof) due at time of payment computed at rates not less than those contained in the wage determination of the Secretary of Labor which is attached hereto and made a part hereof, regardless of any contractual relationship which may be alleged to exist between the Contractor and such laborers and mechanics.

Contributions made or costs reasonably anticipated for bona fide fringe benefits under section 1(b)(2) of the Davis-Bacon Act on behalf of laborers or mechanics are considered wages paid to such laborers or mechanics, subject to the provisions of paragraph (1)(iv) of this section; also, regular contributions made or costs incurred for more than a weekly period (but not less often than quarterly) under plans, funds, or programs which cover the particular weekly period, are deemed to be constructively made or incurred during such weekly period. Such laborers and mechanics shall be paid the appropriate wage rate and fringe benefits on the wage determination for the classification of work actually performed, without regard to skill, except as provided in 29 CFR § 5.5(a)(4). Laborers or mechanics performing work in more than one classification may be compensated at the rate specified for each classification for the time actually worked therein: *Provided*, that the employer's payroll records accurately set forth the time spent in each classification in which work is performed. The wage determination (including any additional classification and wage rates conformed under (1)(ii) of this section) and the Davis-Bacon poster (WH-1321) shall be posted at all times by the Contractor and its subcontractors at the site of the work in a prominent and accessible place where it can easily be seen by the workers.

(ii)(A) The contracting officer shall require that any class of laborers or mechanics, including helpers, which is not listed in the wage determination and which is to be employed under the contract shall be classified in conformance with the wage determination. The contracting officer shall approve an additional classification and wage rate and fringe benefits therefore only when the following criteria have been met:

- (1) The work to be performed by the classification requested is not performed by a classification in the wage determination;
- (2) The classification is utilized in the area by the construction industry; and
- (3) The proposed wage rate, including any bona fide fringe benefits, bears a reasonable relationship to the wage rates contained in the wage determination.

(B) If the Contractor and the laborers and mechanics to be employed in the classification (if known), or their representatives, and the contracting officer agree on the classification and wage rate (including the amount designated for fringe benefits where appropriate), a report of the action taken shall be sent by the contracting officer to the Administrator of the Wage and Hour Division, U.S. Department of Labor, Washington, DC 20210. The Administrator, or an authorized representative, will approve, modify, or disapprove every additional classification action within 30 days of receipt and so advise the contracting officer or will notify the contracting officer within the 30-day period that additional time is necessary.

(C) In the event the Contractor, the laborers, or mechanics to be employed in the classification, or their representatives, and the contracting officer do not agree on the proposed classification and wage rate (including the amount designated for fringe benefits, where appropriate), the contracting officer shall refer the questions, including the views of all

interested parties and the recommendation of the contracting officer, to the Administrator for determination. The Administrator, or an authorized representative, will issue a determination within 30 days of receipt and so advise the contracting officer or will notify the contracting officer within the 30-day period that additional time is necessary.

(D) The wage rate (including fringe benefits where appropriate) determined pursuant to subparagraphs (1)(ii) (B) or (C) of this paragraph, shall be paid to all workers performing work in the classification under this contract from the first day on which work is performed in the classification.

(iii) Whenever the minimum wage rate prescribed in the contract for a class of laborers or mechanics includes a fringe benefit which is not expressed as an hourly rate, the contractor shall either pay the benefit as stated in the wage determination or shall pay another bona fide fringe benefit or an hourly cash equivalent thereof.

(iv) If the Contractor does not make payments to a trustee or other third person, the Contractor may consider as part of the wages of any laborer or mechanic the amount of any costs reasonably anticipated in providing bona fide fringe benefits under a plan or program, *Provided*, that the Secretary of Labor has found, upon the written request of the Contractor, that the applicable standards of the Davis-Bacon Act have been met. The Secretary of Labor may require the Contractor to set aside in a separate account assets for the meeting of obligations under the plan or program.

2. Withholding. The Federal Aviation Administration or the Sponsor shall upon its own action or upon written request of an authorized representative of the Department of Labor withhold or cause to be withheld from the Contractor under this contract or any other Federal contract with the same prime contractor, or any other federally-assisted contract subject to Davis-Bacon prevailing wage requirements, which is held by the same prime contractor, so much of the accrued payments or advances as may be considered necessary to pay laborers and mechanics, including apprentices, trainees, and helpers, employed by the Contractor or any subcontractor the full amount of wages required by the contract. In the event of failure to pay any laborer or mechanic, including any apprentice, trainee, or helper, employed or working on the site of the work, all or part of the wages required by the contract, the Federal Aviation Administration may, after written notice to the Contractor, Sponsor, Applicant, or Owner, take such action as may be necessary to cause the suspension of any further payment, advance, or guarantee of funds until such violations have ceased.

3. Payrolls and Basic Records.

(i) Payrolls and basic records relating thereto shall be maintained by the Contractor during the course of the work and preserved for a period of three years thereafter for all laborers and mechanics working at the site of the work. Such records shall contain the name, address, and social security number of each such worker; his or her correct classification; hourly rates of wages paid (including rates of contributions or costs anticipated for bona fide fringe benefits or cash equivalents thereof of the types described in 1(b)(2)(B) of the Davis-Bacon Act); daily and weekly number of hours worked; deductions made; and actual wages paid. Whenever the Secretary of Labor has found under 29 CFR 5.5(a)(1)(iv) that the wages of any laborer or mechanic include the amount of any costs reasonably anticipated in providing benefits under a plan or program described in section 1(b)(2)(B) of the Davis-Bacon Act, the Contractor shall maintain records that show that the commitment to provide such benefits is enforceable, that the plan or program is financially responsible, and that the plan or program has been communicated in writing to the laborers or mechanics affected, and records which show the costs anticipated or the actual costs incurred in providing such benefits. Contractors employing apprentices or trainees under approved programs shall maintain written evidence of the registration of apprenticeship programs and certification of trainee programs, the registration of the apprentices and trainees, and the ratios and wage rates prescribed in the applicable programs.

(ii)(A) The Contractor shall submit weekly for each week in which any contract work is performed a copy of all payrolls to the Federal Aviation Administration if the agency is a party to the contract, but if the agency is not such a party, the Contractor will submit the payrolls to the applicant, Sponsor, or Owner, as the case may be, for transmission to the Federal Aviation Administration. The payrolls submitted shall set out accurately and completely all of the information

required to be maintained under 29 CFR § 5.5(a)(3)(i), except that full social security numbers and home addresses shall not be included on weekly transmittals. Instead the payrolls shall only need to include an individually identifying number for each employee (e.g., the last four digits of the employee's social security number). The required weekly payroll information may be submitted in any form desired. Optional Form WH-347 is available for this purpose from the Wage and Hour Division Web site at <https://www.dol.gov/agencies/whd/government-contracts/construction/payroll-certification> or its successor site. The prime contractor is responsible for the submission of copies of payrolls by all subcontractors. Contractors and subcontractors shall maintain the full social security number and current address of each covered worker and shall provide them upon request to the Federal Aviation Administration if the agency is a party to the contract, but if the agency is not such a party, the Contractor will submit them to the applicant, Sponsor, or Owner, as the case may be, for transmission to the Federal Aviation Administration, the Contractor, or the Wage and Hour Division of the Department of Labor for purposes of an investigation or audit of compliance with prevailing wage requirements. It is not a violation of this section for a prime contractor to require a subcontractor to provide addresses and social security numbers to the prime contractor for its own records, without weekly submission to the sponsoring government agency (or the applicant, Sponsor, or Owner).

(B) Each payroll submitted shall be accompanied by a "Statement of Compliance," signed by the Contractor or subcontractor or his or her agent who pays or supervises the payment of the persons employed under the contract and shall certify the following:

(1) That the payroll for the payroll period contains the information required to be provided under 29 CFR § 5.5(a)(3)(ii), the appropriate information is being maintained under 29 CFR § 5.5 (a)(3)(i), and that such information is correct and complete;

(2) That each laborer and mechanic (including each helper, apprentice, and trainee) employed on the contract during the payroll period has been paid the full weekly wages earned, without rebate, either directly or indirectly, and that no deductions have been made either directly or indirectly from the full wages earned, other than permissible deductions as set forth in Regulations, 29 CFR Part 3;

(3) That each laborer or mechanic has been paid not less than the applicable wage rates and fringe benefits or cash equivalents for the classification of work performed, as specified in the applicable wage determination incorporated into the contract.

(C) The weekly submission of a properly executed certification set forth on the reverse side of Optional Form WH-347 shall satisfy the requirement for submission of the "Statement of Compliance" required by paragraph (3)(ii)(B) of this section.

(D) The falsification of any of the above certifications may subject the Contractor or subcontractor to civil or criminal prosecution under Section 1001 of Title 18 and Section 231 of Title 31 of the United States Code.

(iii) The Contractor or subcontractor shall make the records required under paragraph (3)(i) of this section available for inspection, copying, or transcription by authorized representatives of the Sponsor, the Federal Aviation Administration, or the Department of Labor and shall permit such representatives to interview employees during working hours on the job. If the Contractor or subcontractor fails to submit the required records or to make them available, the Federal agency may, after written notice to the Contractor, Sponsor, applicant, or Owner, take such action as may be necessary to cause the suspension of any further payment, advance, or guarantee of funds. Furthermore, failure to submit the required records upon request or to make such records available may be grounds for debarment action pursuant to 29 CFR § 5.12.

4. Apprentices and Trainees.

(i) Apprentices. Apprentices will be permitted to work at less than the predetermined rate for the work they performed when they are employed pursuant to and individually registered in a bona fide apprenticeship program registered with

the U.S. Department of Labor, Employment and Training Administration, Office of Apprenticeship Training, Employer and Labor Services, or with a State Apprenticeship Agency recognized by the Office, or if a person is employed in his or her first 90 days of probationary employment as an apprentice in such an apprenticeship program, who is not individually registered in the program, but who has been certified by the Office of Apprenticeship Training, Employer and Labor Services or a State Apprenticeship Agency (where appropriate) to be eligible for probationary employment as an apprentice. The allowable ratio of apprentices to journeymen on the job site in any craft classification shall not be greater than the ratio permitted to the contractor as to the entire work force under the registered program. Any worker listed on a payroll at an apprentice wage rate, who is not registered or otherwise employed as stated above, shall be paid not less than the applicable wage rate on the wage determination for the classification of work actually performed. In addition, any apprentice performing work on the job site in excess of the ratio permitted under the registered program shall be paid not less than the applicable wage rate on the wage determination for the work actually performed. Where a contractor is performing construction on a project in a locality other than that in which its program is registered, the ratios and wage rates (expressed in percentages of the journeyman's hourly rate) specified in the Contractor's or subcontractor's registered program shall be observed. Every apprentice must be paid at not less than the rate specified in the registered program for the apprentice's level of progress, expressed as a percentage of the journeymen hourly rate specified in the applicable wage determination. Apprentices shall be paid fringe benefits in accordance with the provisions of the apprenticeship program. If the apprenticeship program does not specify fringe benefits, apprentices must be paid the full amount of fringe benefits listed on the wage determination for the applicable classification. If the Administrator determines that a different practice prevails for the applicable apprentice classification, fringes shall be paid in accordance with that determination. In the event the Office of Apprenticeship Training, Employer and Labor Services, or a State Apprenticeship Agency recognized by the Office, withdraws approval of an apprenticeship program, the Contractor will no longer be permitted to utilize apprentices at less than the applicable predetermined rate for the work performed until an acceptable program is approved.

(ii) Trainees. Except as provided in 29 CFR § 5.16, trainees will not be permitted to work at less than the predetermined rate for the work performed unless they are employed pursuant to and individually registered in a program which has received prior approval, evidenced by formal certification by the U.S. Department of Labor, Employment and Training Administration. The ratio of trainees to journeymen on the job site shall not be greater than permitted under the plan approved by the Employment and Training Administration. Every trainee must be paid at not less than the rate specified in the approved program for the trainee's level of progress, expressed as a percentage of the journeyman hourly rate specified in the applicable wage determination. Trainees shall be paid fringe benefits in accordance with the provisions of the trainee program. If the trainee program does not mention fringe benefits, trainees shall be paid the full amount of fringe benefits listed on the wage determination unless the Administrator of the Wage and Hour Division determines that there is an apprenticeship program associated with the corresponding journeyman wage rate on the wage determination that provides for less than full fringe benefits for apprentices. Any employee listed on the payroll at a trainee rate that is not registered and participating in a training plan approved by the Employment and Training Administration shall be paid not less than the applicable wage rate on the wage determination for the classification of work actually performed. In addition, any trainee performing work on the job site in excess of the ratio permitted under the registered program shall be paid not less than the applicable wage rate on the wage determination for the work actually performed. In the event the Employment and Training Administration withdraws approval of a training program, the Contractor will no longer be permitted to utilize trainees at less than the applicable predetermined rate for the work performed until an acceptable program is approved.

(iii) Equal Employment Opportunity. The utilization of apprentices, trainees, and journeymen under this part shall be in conformity with the equal employment opportunity requirements of Executive Order 11246, as amended, and 29 CFR Part 30.

5. Compliance with Copeland Act Requirements.

The Contractor shall comply with the requirements of 29 CFR Part 3, which are incorporated by reference in this contract.

6. Subcontracts.

The Contractor or subcontractor shall insert in any subcontracts the clauses contained in 29 CFR §§ 5.5(a)(1) through (10) and such other clauses as the Federal Aviation Administration may by appropriate instructions require, and also a clause requiring the subcontractors to include these clauses in any lower tier subcontracts. The prime contractor shall be responsible for the compliance by any subcontractor or lower tier subcontractor with all the contract clauses in 29 CFR § 5.5.

7. Contract Termination: Debarment.

A breach of the contract clauses in paragraph 1 through 10 of this section may be grounds for termination of the contract, and for debarment as a contractor and a subcontractor as provided in 29 CFR § 5.12.

8. Compliance with Davis-Bacon and Related Act Requirements.

All rulings and interpretations of the Davis-Bacon and Related Acts contained in 29 CFR Parts 1, 3, and 5 are herein incorporated by reference in this contract.

9. Disputes Concerning Labor Standards.

Disputes arising out of the labor standards provisions of this contract shall not be subject to the general disputes clause of this contract. Such disputes shall be resolved in accordance with the procedures of the Department of Labor set forth in 29 CFR Parts 5, 6, and 7. Disputes within the meaning of this clause include disputes between the Contractor (or any of its subcontractors) and the contracting agency, the U.S. Department of Labor, or the employees or their representatives.

10. Certification of Eligibility.

(i) By entering into this contract, the Contractor certifies that neither it (nor he or she) nor any person or firm who has an interest in the Contractor's firm is a person or firm ineligible to be awarded Government contracts by virtue of section 3(a) of the Davis-Bacon Act or 29 CFR § 5.12(a)(1).

(ii) No part of this contract shall be subcontracted to any person or firm ineligible for award of a Government contract by virtue of section 3(a) of the Davis-Bacon Act or 29 CFR § 5.12(a)(1).

(iii) The penalty for making false statements is prescribed in the U.S. Criminal Code, 18 USC § 1001.

CERTIFICATION OF OFFEROR/BIDDER REGARDING DEBARMENT

By submitting a bid/proposal under this solicitation, the bidder or offeror certifies that neither it nor its principals are presently debarred or suspended by any Federal department or agency from participation in this transaction.

DISADVANTAGED BUSINESS ENTERPRISE

Bid Information Submitted as a matter of responsiveness:

The Owner's award of this contract is conditioned upon Bidder or Offeror satisfying the good faith effort requirements of 49 CFR § 26.53.

As a condition of responsiveness, the Bidder or Offeror must submit the following information with its proposal on the forms provided herein:

- 1) The names and addresses of Disadvantaged Business Enterprise (DBE) firms that will participate in the contract;
- 2) A description of the work that each DBE firm will perform;
- 3) The dollar amount of the participation of each DBE firm listed under (1);
- 4) Written statement from Bidder or Offeror that attests their commitment to use the DBE firm(s) listed under (1) to meet the Owner's project goal
- 5) Written confirmation from each listed DBE firm that it is participating in the contract in the kind and amount of work provided in the prime contractor's commitment; and
- 6) If Bidder or Offeror cannot meet the advertised project DBE goal, evidence of good faith efforts undertaken by the Bidder or Offeror as described in appendix A to 49 CFR part 26. The documentation of good faith efforts must include copies of each DBE and non-DBE subcontractor quote submitted to the bidder when a non-DBE subcontractor was selected over a DBE for work on the contract.

Bid Information submitted as a matter of responsibility:

The Owner's award of this contract is conditioned upon Bidder or Offeror satisfying the good faith effort requirements of 49 CFR § 26.53.

As a condition of responsibility, every Bidder or Offeror must submit the following information on the forms provided herein within five days after bid opening.

- 1) The names and addresses of Disadvantaged Business Enterprise (DBE) firms that will participate in the contract;
- 2) A description of the work that each DBE firm will perform;
- 3) The dollar amount of the participation of each DBE firm listed under (1);
- 4) Written statement from Bidder or Offeror that attests their commitment to use the DBE firm(s) listed under (1) to meet the Owner's project goal;
- 5) Written confirmation from each listed DBE firm that it is participating in the contract in the kind and amount of work provided in the prime contractor's commitment; and
- 6) If Bidder or Offeror cannot meet the advertised project DBE goal, evidence of good faith efforts undertaken by the Bidder or Offeror as described in appendix A to 49 CFR part 26. The documentation of good faith efforts must include copies of each DBE and non-DBE subcontractor quote submitted to the bidder when a non-DBE subcontractor was selected over a DBE for work on the contract.

Contract Assurance (49 CFR § 26.13; mandatory text provided) –

The Contractor, subrecipient or subcontractor shall not discriminate on the basis of race, color, national origin, or sex in the performance of this contract. The Contractor shall carry out applicable requirements of 49 CFR part 26 in the award

and administration of DOT-assisted contracts. Failure by the Contractor to carry out these requirements is a material breach of this contract, which may result in the termination of this contract or such other remedy as the recipient deems appropriate, which may include, but is not limited to:

- 1) Withholding monthly progress payments;
- 2) Assessing sanctions;
- 3) Liquidated damages; and/or
- 4) Disqualifying the Contractor from future bidding as non-responsible.

Prompt Payment (49 CFR § 26.29; acceptable/sample text provided) –

The prime contractor agrees to pay each subcontractor under this prime contract for satisfactory performance of its contract no later than [specify number of days, not to exceed 30] days from the receipt of each payment the prime contractor receives from [Name of recipient]. The prime contractor agrees further to return retainage payments to each subcontractor within [specify number of days, not to exceed 30] days after the subcontractor's work is satisfactorily completed. Any delay or postponement of payment from the above referenced time frame may occur only for good cause following written approval of the [Name of Recipient]. This clause applies to both DBE and non-DBE subcontractors.

Termination of DBE Subcontracts (49 CFR § 26.53(f); acceptable/sample text provided) –

The prime contractor must not terminate a DBE subcontractor listed in response to [include Solicitation paragraph number where paragraph 12.3.1, Solicitation Language appears] (or an approved substitute DBE firm) without prior written consent of [Name of Recipient]. This includes, but is not limited to, instances in which the prime contractor seeks to perform work originally designated for a DBE subcontractor with its own forces or those of an affiliate, a non-DBE firm, or with another DBE firm.

The prime contractor shall utilize the specific DBEs listed to perform the work and supply the materials for which each is listed unless the contractor obtains written consent [Name of Recipient]. Unless [Name of Recipient] consent is provided, the prime contractor shall not be entitled to any payment for work or material unless it is performed or supplied by the listed DBE.

[Name of Recipient] may provide such written consent only if [Name of Recipient] agrees, for reasons stated in the concurrence document, that the prime contractor has good cause to terminate the DBE firm. For purposes of this paragraph, good cause includes the circumstances listed in 49 CFR §26.53.

Before transmitting to [Name of Recipient] its request to terminate and/or substitute a DBE subcontractor, the prime contractor must give notice in writing to the DBE subcontractor, with a copy to [Name of Recipient], of its intent to request to terminate and/or substitute, and the reason for the request.

The prime contractor must give the DBE five days to respond to the prime contractor's notice and advise [Name of Recipient] and the contractor of the reasons, if any, why it objects to the proposed termination of its subcontract and why [Name of Recipient] should not approve the prime contractor's action. If required in a particular case as a matter of public necessity (e.g., safety), [Name of Recipient] may provide a response period shorter than five days.

In addition to post-award terminations, the provisions of this section apply to preaward deletions of or substitutions for DBE firms put forward by offerors in negotiated procurements.

Federal Fair Labor Standards Act

All contracts and subcontracts that result from this solicitation incorporate by reference the provisions of 29 CFR part 201, et seq, the Federal Fair Labor Standards Act (FLSA), with the same force and effect as if given in full text. The FLSA sets minimum wage, overtime pay, recordkeeping, and child labor standards for full and part-time workers.

The [Contractor | Consultant] has full responsibility to monitor compliance to the referenced statute or regulation. The [Contractor | Consultant] must address any claims or disputes that arise from this requirement directly with the U.S. Department of Labor – Wage and Hour Division.

TRADE RESTRICTION CERTIFICATION

By submission of an offer, the Offeror certifies that with respect to this solicitation and any resultant contract, the Offeror –

- 1) is not owned or controlled by one or more citizens of a foreign country included in the list of countries that discriminate against U.S. firms as published by the Office of the United States Trade Representative (USTR);
- 2) has not knowingly entered into any contract or subcontract for this project with a person that is a citizen or national of a foreign country included on the list of countries that discriminate against U.S. firms as published by the USTR; and
- 3) has not entered into any subcontract for any product to be used on the Federal project that is produced in a foreign country included on the list of countries that discriminate against U.S. firms published by the USTR.

This certification concerns a matter within the jurisdiction of an agency of the United States of America and the making of a false, fictitious, or fraudulent certification may render the maker subject to prosecution under Title 18 USC § 1001.

The Offeror/Contractor must provide immediate written notice to the Owner if the Offeror/Contractor learns that its certification or that of a subcontractor was erroneous when submitted or has become erroneous by reason of changed circumstances. The Contractor must require subcontractors provide immediate written notice to the Contractor if at any time it learns that its certification was erroneous by reason of changed circumstances.

Unless the restrictions of this clause are waived by the Secretary of Transportation in accordance with 49 CFR § 30.17, no contract shall be awarded to an Offeror or subcontractor:

- 1) who is owned or controlled by one or more citizens or nationals of a foreign country included on the list of countries that discriminate against U.S. firms published by the USTR; or
- 2) whose subcontractors are owned or controlled by one or more citizens or nationals of a foreign country on such USTR list; or
- 3) who incorporates in the public works project any product of a foreign country on such USTR list.

Nothing contained in the foregoing shall be construed to require establishment of a system of records in order to render, in good faith, the certification required by this provision. The knowledge and information of a contractor is not required to exceed that which is normally possessed by a prudent person in the ordinary course of business dealings.

The Offeror agrees that, if awarded a contract resulting from this solicitation, it will incorporate this provision for certification without modification in all lower tier subcontracts. The Contractor may rely on the certification of a prospective subcontractor that it is not a firm from a foreign country included on the list of countries that discriminate against U.S. firms as published by USTR, unless the Offeror has knowledge that the certification is erroneous.

This certification is a material representation of fact upon which reliance was placed when making an award. If it is later determined that the Contractor or subcontractor knowingly rendered an erroneous certification, the Federal Aviation Administration (FAA) may direct through the Owner cancellation of the contract or subcontract for default at no cost to the Owner or the FAA.

CERTIFICATION REGARDING LOBBYING

The Bidder or Offeror certifies by signing and submitting this bid or proposal, to the best of his or her knowledge and belief, that:

- (1) No Federal appropriated funds have been paid or will be paid, by or on behalf of the Bidder or Offeror, to any person for influencing or attempting to influence an officer or employee of an agency, a Member of Congress, an officer or employee of Congress, or an employee of a Member of Congress in connection with the awarding of any Federal contract, the making of any Federal grant, the making of any Federal loan, the entering into of any cooperative agreement, and the extension, continuation, renewal, amendment, or modification of any Federal contract, grant, loan, or cooperative agreement.
- (2) If any funds other than Federal appropriated funds have been paid or will be paid to any person for influencing or attempting to influence an officer or employee of any agency, a Member of Congress, an officer or employee of Congress, or an employee of a Member of Congress in connection with this Federal contract, grant, loan, or cooperative agreement, the undersigned shall complete and submit Standard Form-LLL, "Disclosure Form to Report Lobbying," in accordance with its instructions.
- (3) The undersigned shall require that the language of this certification be included in the award documents for all sub-awards at all tiers (including subcontracts, subgrants, and contracts under grants, loans, and cooperative agreements) and that all sub-recipients shall certify and disclose accordingly.

This certification is a material representation of fact upon which reliance was placed when this transaction was made or entered into. Submission of this certification is a prerequisite for making or entering into this transaction imposed by section 1352, title 31, U.S. Code. Any person who fails to file the required certification shall be subject to a civil penalty of not less than \$10,000 and not more than \$100,000 for each such failure.

PROCUREMENT OF RECOVERED MATERIALS

Contractor and subcontractor agree to comply with Section 6002 of the Solid Waste Disposal Act, as amended by the Resource Conservation and Recovery Act, and the regulatory provisions of 40 CFR Part 247. In the performance of this contract and to the extent practicable, the Contractor and subcontractors are to use products containing the highest percentage of recovered materials for items designated by the Environmental Protection Agency (EPA) under 40 CFR Part 247 whenever:

- 1) The contract requires procurement of \$10,000 or more of a designated item during the fiscal year; or
- 2) The contractor has procured \$10,000 or more of a designated item using Federal funding during the previous fiscal year.

The list of EPA-designated items is available at www.epa.gov/smm/comprehensive-procurement-guidelines-construction-products.

Section 6002(c) establishes exceptions to the preference for recovery of EPA-designated products if the contractor can demonstrate the item is:

- a) Not reasonably available within a timeframe providing for compliance with the contract performance schedule;
- b) Fails to meet reasonable contract performance requirements; or
- c) Is only available at an unreasonable price.

EXHIBITS

Exhibit A – 2023 PCI

See next page

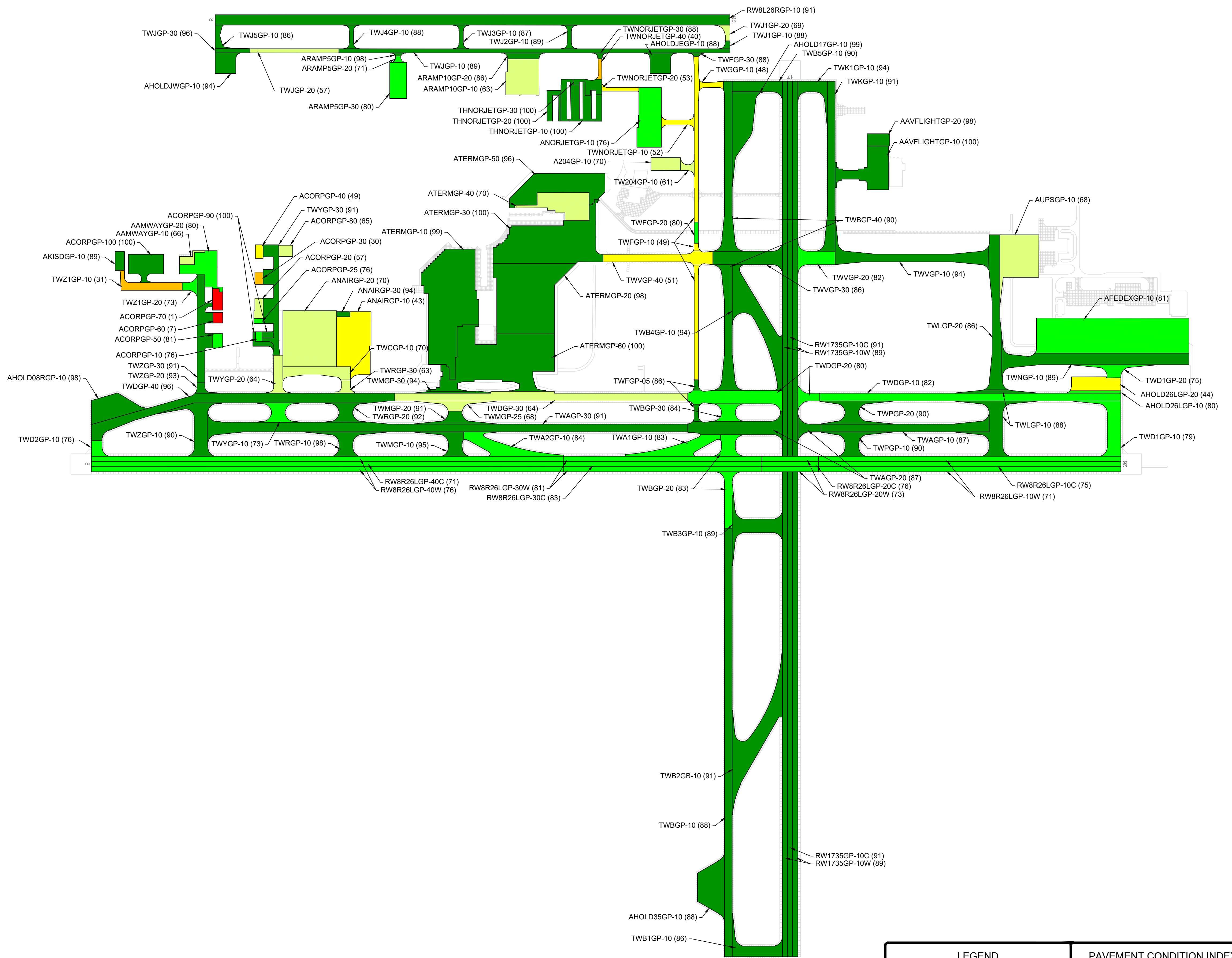

LEGEND

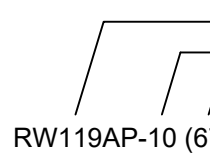
 BRANCH IDENTIFIER
SECTION IDENTIFIER
PCI VALUE

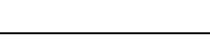
 SECTION BREAK LINE

PAVEMENT CONDITION INDEX

PCI	REPAIR
100	PREVENTIVE MAINTENANCE
85	MAJOR REHABILITATION
70	RECONSTRUCTION
55	
40	
25	
10	
0	

applied pavement TECHNOLOGY 115 W. Main Street, Suite 400
Urbana, IL 61801
Tel: (217) 398-3977
Fax: (217) 398-4027

AGENCY: Michigan Department of Transportation
Office of Aeronautics

LOCATION: Gerald R. Ford International Airport
Grand Rapids, MI

PAGE TITLE: 2023 PAVEMENT CONDITION MAP

PROJECT DATE: OCT. 2022	CREATION DATE: SEP. 2023	PROJECT MANAGER: KMP	JOB NUMBER: 2022-001-AM01
DRAWING SCALE: 1"=300'	LAST MODIFIED DATE: SEP. 2023	REVISED BY: KEW	DRAWN BY: MDK
FILENAME: Grand Rapids.dwg	LAYOUT NAME/NUMBER: PCI	FIGURE: 6	

Exhibit B – GRR ASR Locations

See next page

Exhibit C – Pavement Section Locations with PCRs

See next page

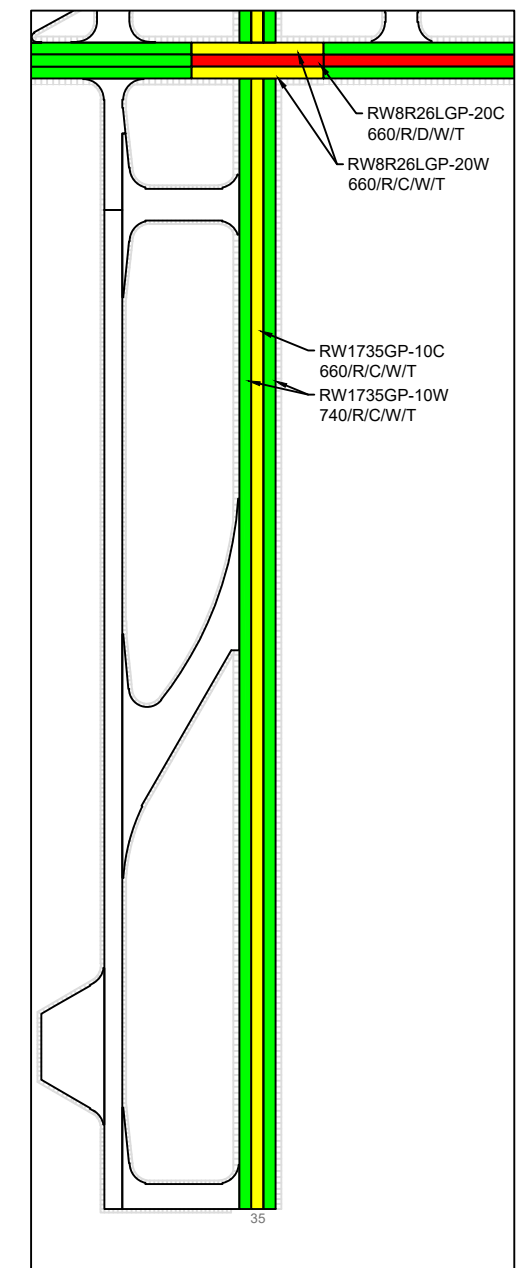
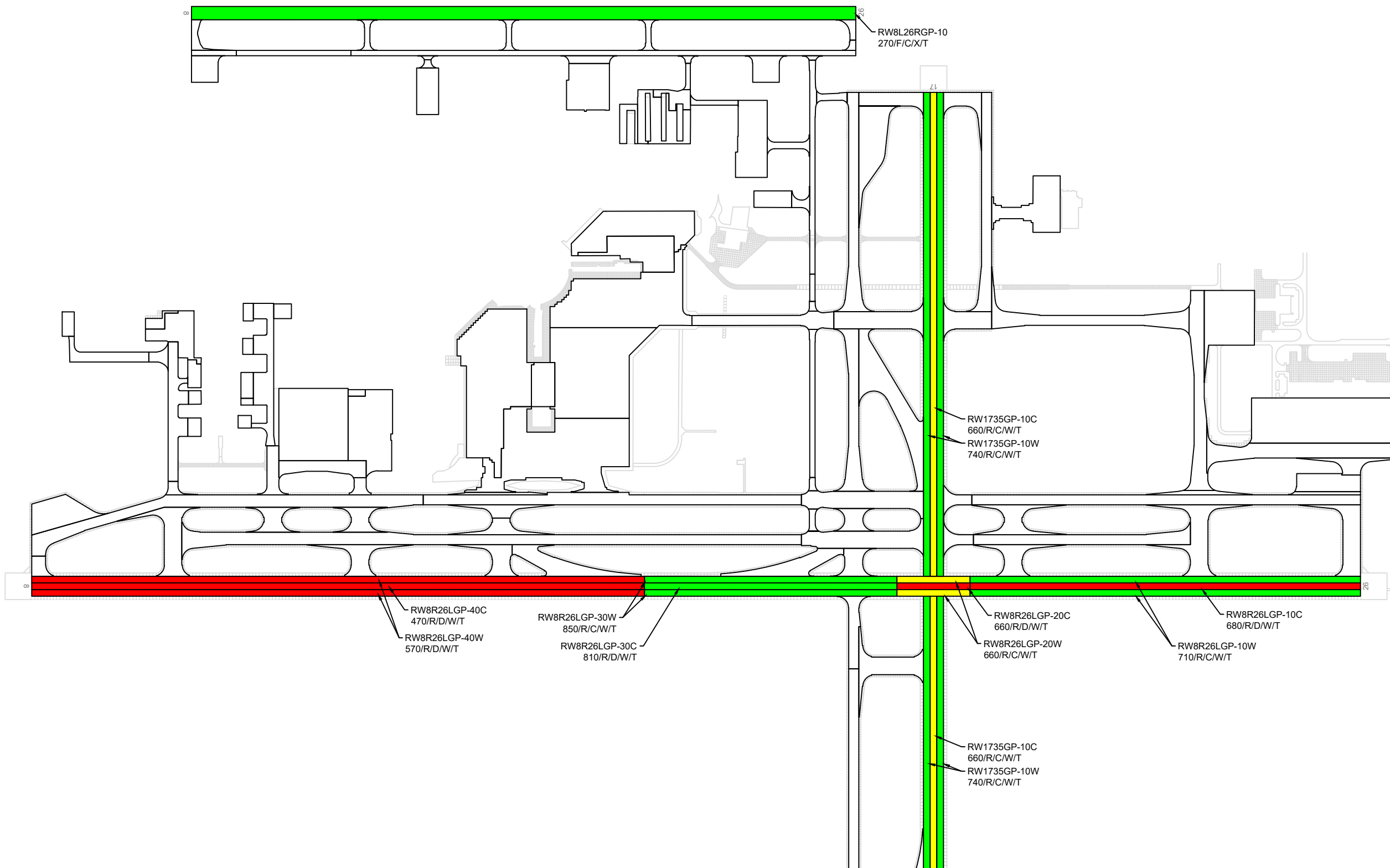

LEGEND

BRANCH IDENTIFIER
SECTION IDENTIFIER
PCR VALUE

SECTION BREAK LINE

LEGEND

STRUCTURALLY ADEQUATE
RESTRICTIONS MAY APPLY
STRUCTURALLY INADEQUATE
NOT EVALUATED

applied pavement TECHNOLOGY
115 W. Main Street, Suite 400
Urbana, IL 61801
Tel: (217) 398-3977
Fax: (217) 398-4027

AGENCY: Michigan Department of Transportation
Office of Aeronautics

LOCATION: Gerald R. Ford International Airport
Grand Rapids, MI

PAGE TITLE: PCR Assessment Map

PROJECT DATE: FEB. 2020	CREATION DATE: JUN. 2020	PROJECT MANAGER: KMP	JOB NUMBER: 2020-098-AM01
DRAWING SCALE: 1" = 900'	LAST MODIFIED DATE: JAN. 2023	REVISED BY: KEW	DRAWN BY: KEW
FILENAME: Grand Rapids.dwg	LAYOUT NAME/NUMBER: PCR	FIGURE NUMBER: A-1	