



TO: Vendors

FROM: AJ Nye – Procurement Specialist

Subject: RFQ 2518: RWY 8R/26L Rehabilitation Consulting: Addendum 1 – Pre-Bid Notes, Q&A, and Solicitation Errors

Date: 5/27/2025

---

**NOTE:**

The following Addendum No. 1 is issued by the Gerald R. Ford International Airport Authority to recap the Pre-Submission Meeting, as well as make corrections to the original Request for Qualifications document. This addendum includes:

- Pre-Submission Sign-In Sheet
- Pre-Submission Agenda
- Pre-Submission Slide Deck
- Questions & Answers document from received questions.
- Corrections to RFQ Document:
  - Additional pages given to “References” section of evaluation format.
  - Correction and clarification of scoring matrix.
  - Removal of duplicate submission criteria.
- Additional Exhibit:
  - 2023 Pavement Management Report

Thank you.

[End of Addendum 1]

---



## SIGN IN SHEET

RFP 2518 – Pre-Proposal Meeting

May 20, 2025 @ 9:00 am

	Business Name	Attendee	Email
1	G F I A A	Clint Nemeth	<a href="mailto:cnemeth@grr.org">cnemeth@grr.org</a>
2	G F I A A	Tom Cizauskas	<a href="mailto:tcizauskas@grr.org">tcizauskas@grr.org</a>
3	G F I A A	AJ Nye	<a href="mailto:anye@grr.org">anye@grr.org</a>
4	F o t h	Nate Granger	<a href="mailto:Nate.granger@foth.com">Nate.granger@foth.com</a>
5	R S & H	David Joye	<a href="mailto:David.joye@rsandh.com">David.joye@rsandh.com</a>
6	R S & H	Nick Patterson	<a href="mailto:Nick.patterson@rsandh.com">Nick.patterson@rsandh.com</a>
7	M e a d & H u n t	Bob Leisering	<a href="mailto:Bob.leisering@meadhunt.com">Bob.leisering@meadhunt.com</a>
8	M e a d & H u n t	Jeff Thoman	<a href="mailto:jeff.thoman@meadhunt.com">jeff.thoman@meadhunt.com</a>
9	P r e i n & N e w h o f	Brian Merk	<a href="mailto:bmerk@preinnewhof.com">bmerk@preinnewhof.com</a>
10	K i m l e y - H o r n	John Stella	<a href="mailto:John.stella@kimley-horn.com">John.stella@kimley-horn.com</a>
11	C & S	Bob Koller	<a href="mailto:rkoller@cscos.com">rkoller@cscos.com</a>
12	C & S	Kelly Jost	<a href="mailto:kjost@cscos.com">kjost@cscos.com</a>



## RFQ 2518 Pre-Submission Conference 05/20/25, 9:00 am

### 1. Introductions - AJ

- Clint Nemeth – Engineering Manager
- Tom Cizauskas – GFIAA Business Administration Manager
- AJ Nye – GFIAA Procurement Specialist

### 2. RFQ Process Overview – AJ

Solicitation Schedule	
RFQ Issue Date	May 2, 2025
Question Deadline	May 22, 2025
Submission Due Date	June 5, 2025 at 2:00 pm

**Submission Format:**

Electronic via dropbox or hard copy

**Evaluation Process:**

Evaluation Matrix including Interviews

### 3. Project Overview - Clint

- Project Needs
- Project Goals
- Expectations

### 4. Questions - AJ

**MEETING NOTES:**

# Runway 8R/26L Rehabilitation Engineering Services

Request #2518

SOQs due June 5, 2025 – 2:00 pm (local)



*Where the going gets good.™*



# GRR Fast Facts

- 2<sup>nd</sup> Largest Airport in Michigan
- 2.93 Million Passengers in 2021
- 3.47 Million Passengers in 2022
- 3.79 Million Passengers in 2023
- 4.10 Million Passengers in 2024
- 3,200 Acres of Land
- \$7.7 B+ of Economic Impact to West Michigan
- Supporting 40,000+ Direct Jobs in West Michigan

# GFIA Economic Impact Highlights

## 40,000 JOBS

SUPPORTED IN WEST MICHIGAN

## \$7.7 BILLION

ECONOMIC IMPACT IN WEST MICHIGAN

## \$1.3 BILLION

CATALYTIC IMPACT ON HOUSEHOLD INCOME

## Economic Service Area

The Gerald R. Ford International Airport is based in Kent County, Michigan, and primarily serves the 13-county West Michigan Economic Development Region. This includes Allegan, Barry, Kent, Ionia, Lake, Mason, Mecosta, Montcalm, Muskegon, Newago, Oceana, Osceola, and Ottawa counties.

### West Michigan Economic Region By The Numbers:

- Population: 1,627,734
- Average Annual Growth Rate (2013-2020): 0.75%
- Median Household Income: \$58.5K

• *WM Regional Dashboard - 2020 - The Right Place*





# GRR Originating Passengers

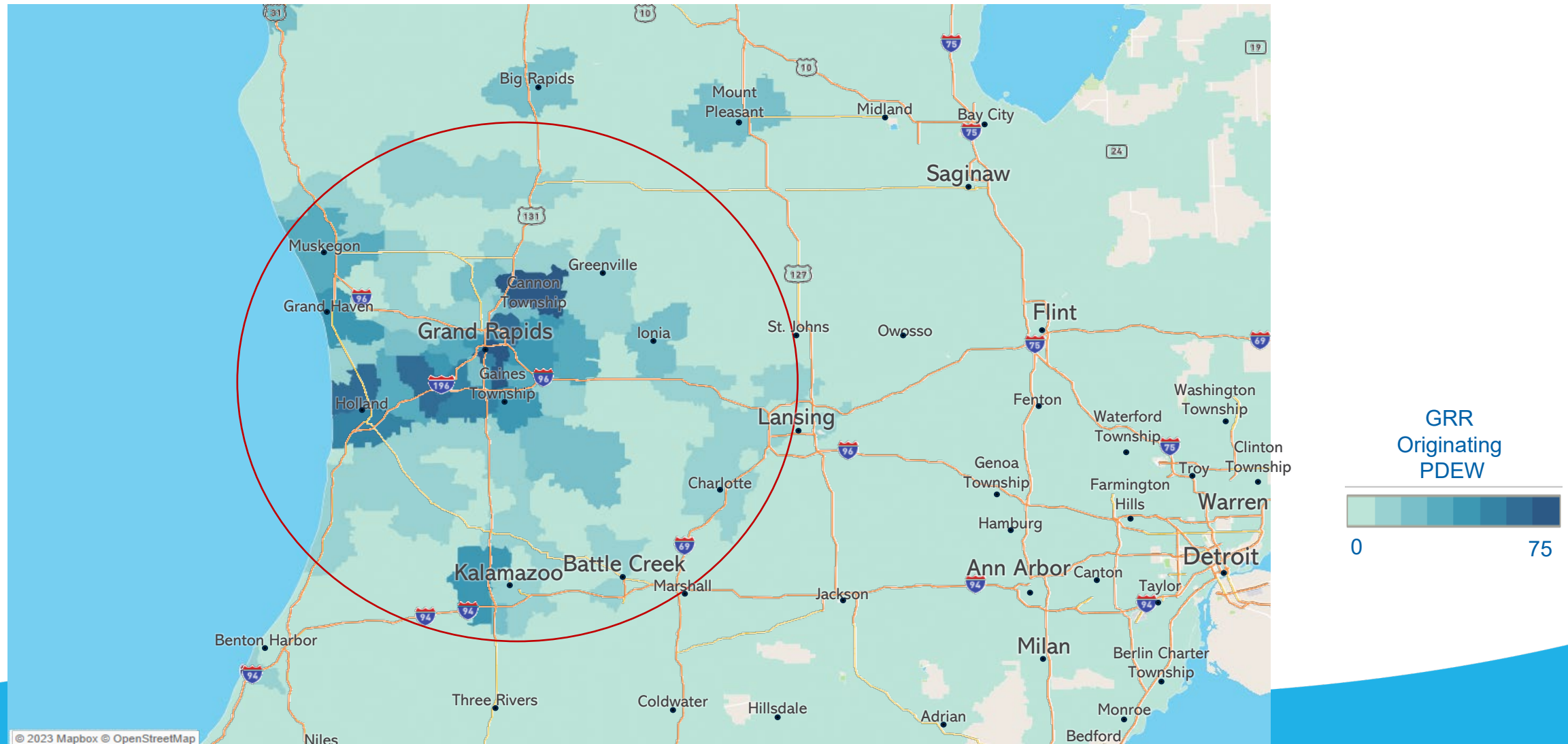

# The GRR AIR Service portfolio is coast-to-coast





# Guest Experience



# Total Yearly Passengers Trend

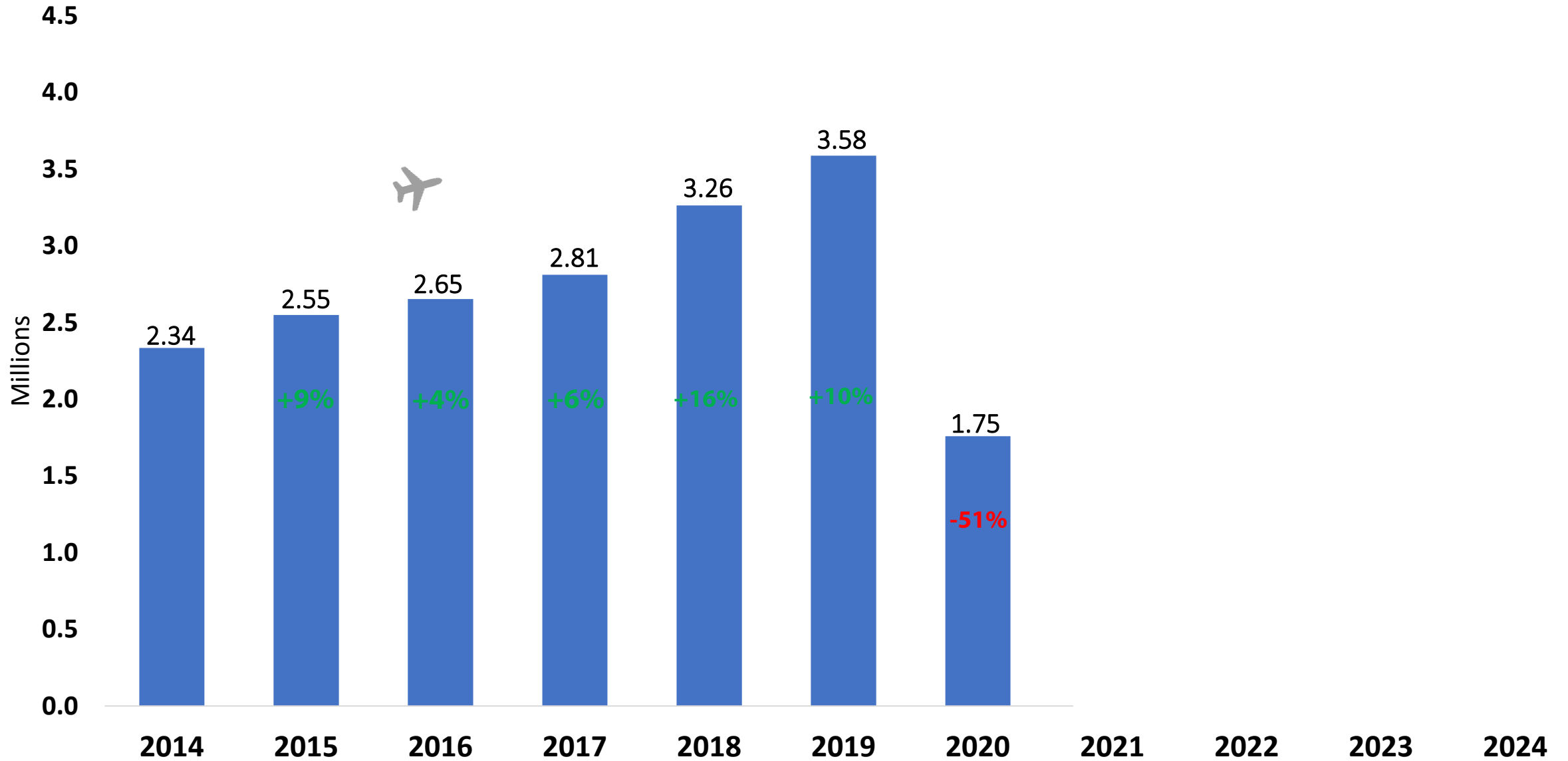

# Passenger Traffic



- 2024 Year to Date – 3.5 million Passengers
- +11.0% from 2023
- +17.0% from 2019

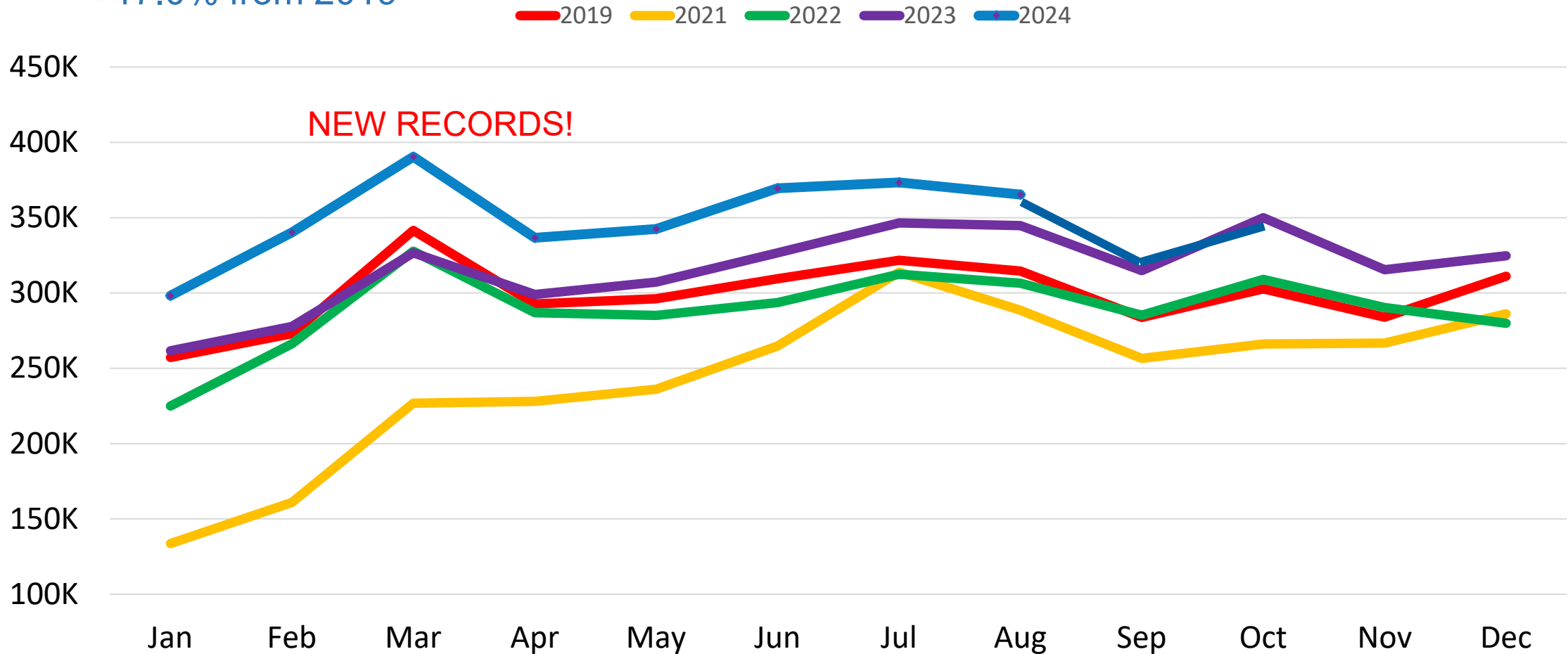

# 2024 Long-term enplaned passenger scenarios

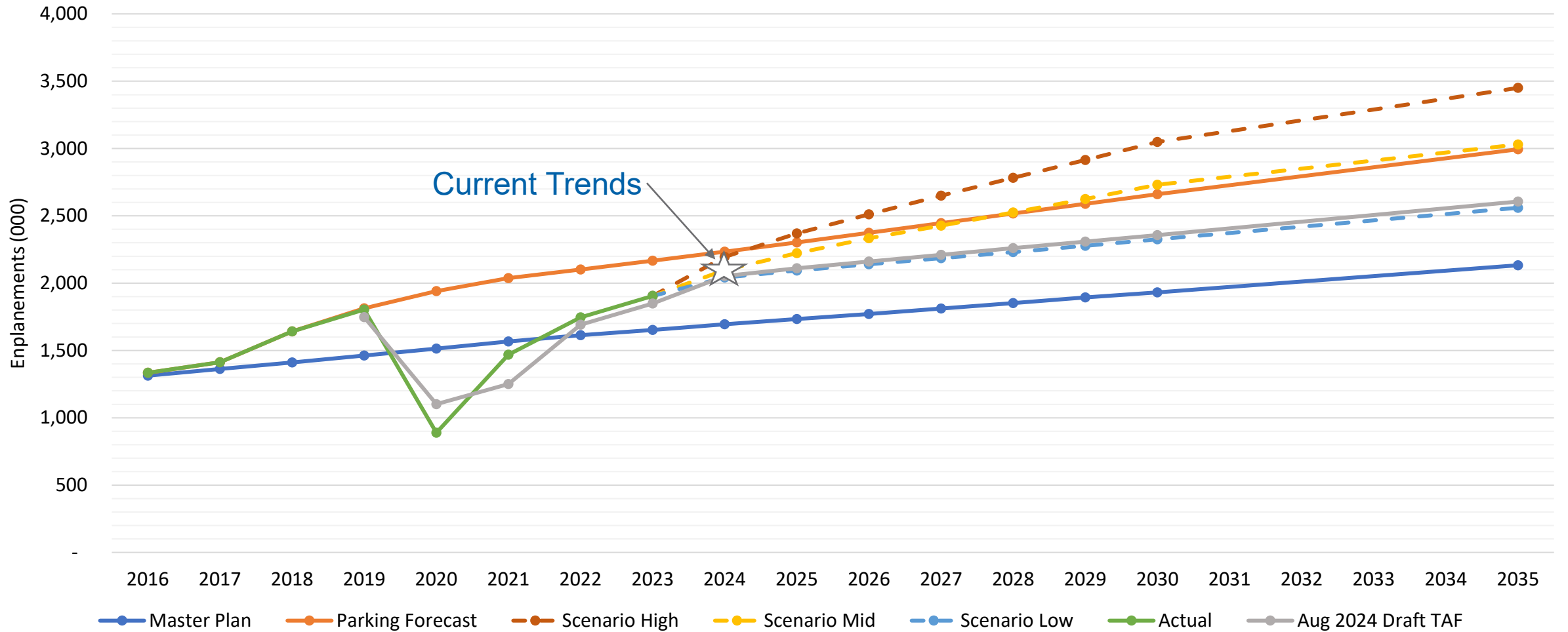



# Runway 8R/26L: RFQ Schedule

## SOLICITATION AND PROJECT SCHEDULE

ACTIVITY	DATE
RFQ Issue Date	May 2, 2025
Voluntary On-Site Conference	May 20, 2025
Question Deadline	May 22, 2025
Submission Due Date	June 5, 2025 at 2 pm
Contract Start Date	July 2025



# Runway 8R/26L: RFQ Work Scope

- Existing Condition Assessment and Reporting
- Development of Preliminary Design Plans, Phasing Strategy, and Cost Estimates
- Operational Impact Mitigation and Phasing Considerations
- Preliminary Design and Financial Planning Support
- Final Design, Specifications, and Bidding Support
- Construction Administration and Closeout Services
- Grant Support and Funding Assistance

# Evaluation Matrix Template



## 125 Points

<b>Evaluation Criteria</b>	<b>Maximum Points</b>	<b>Score</b>	<b>Comments</b>
Executive Summary	0	N/A	Not Scored
Firm Experience and Qualifications	25		
Understanding of Federal Provisions	10		
Approach and Methodology	25		
Key Personnel and Project Team	30		
References	10		
Interview (Shortlist Firms Only)	25		
<b>Total –</b>	<b>100</b>		

# Runway 8R/26L: Existing Pavement Section



- 14" PCC (P-501)
- 10" CTB (P-304)
- 6" Type 1 Sub-Base (P-154)
- 12" Type 2 Sub-Base (P-154)

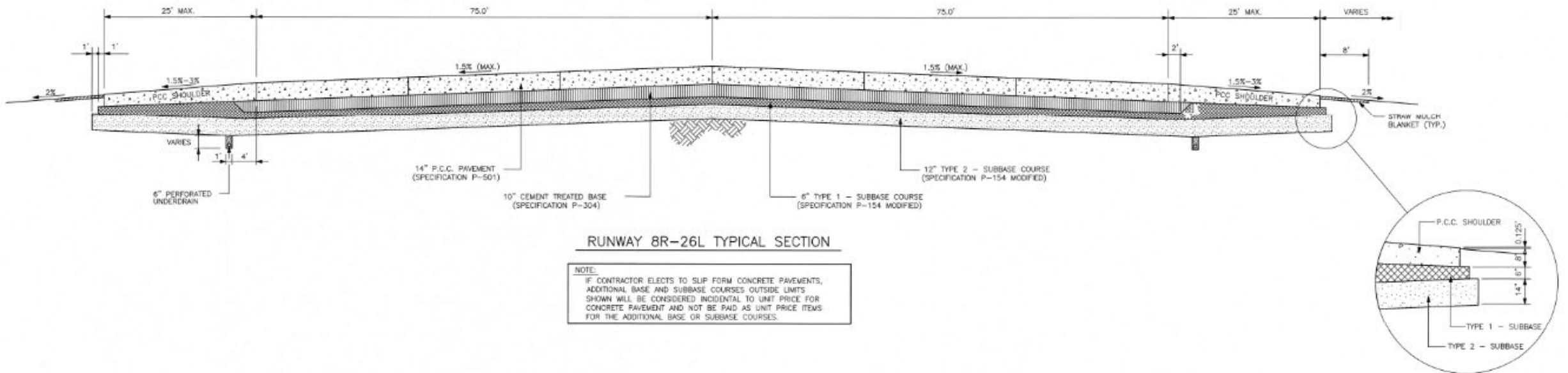



# Runway 8R/26L: Runway Intersection

- Area of concrete pavement within the Runway Safety Areas (RSA) of Runway 8R-26L and 17-35
  - Approximately 14,500 syd
  - Slab size = 25' x 25'
- Critical intersection of airport operations
- Some rehabilitation (white topping) completed in 2017
  - Nighttime construction (last flight in first flight out)

Intersecting Runway Safety Areas (RSA) for Runway 8R-26L and 17-35



# Runway 8R/26L: 2023 PCI Map

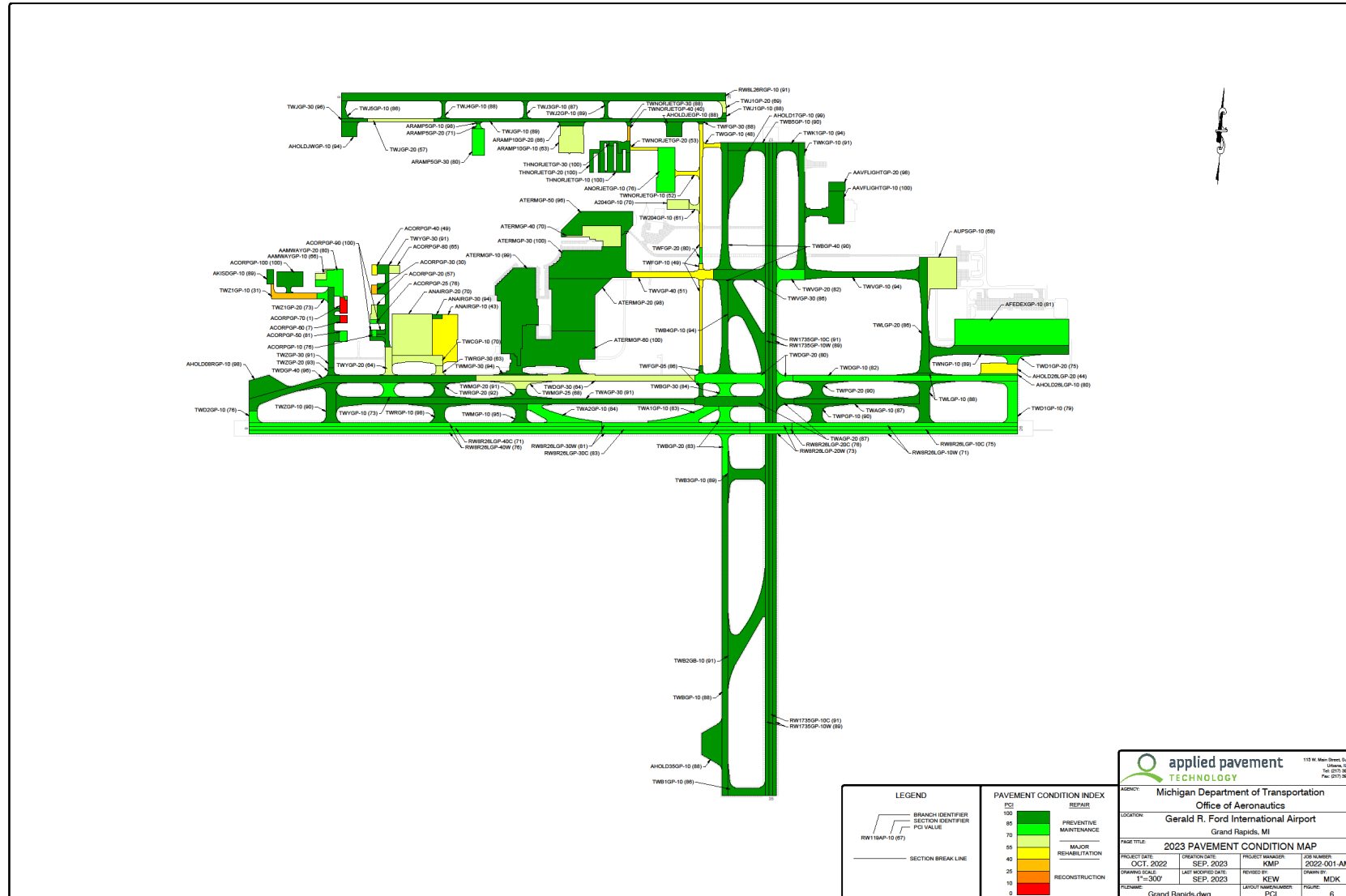

**applied pavement TECHNOLOGY**  
 115 W. Main Street, Suite 400  
 Okemos, MI 48867  
 Tel: (517) 386-8477  
 Fax: (517) 386-8422

AGENCY: Michigan Department of Transportation  
 Office of Aeronautics  
 LOCATION: Gerald R. Ford International Airport  
 Grand Rapids, MI

TITLE: 2023 PAVEMENT CONDITION MAP

PROJECT DATE: OCT 1, 2022	CREATION DATE: SEP, 2023	PROJECT MANAGER: KMP	JOB NUMBER: 2022-001-AM01
DRAWING SCALE: 1"=300'	LAST MODIFIED DATE: SEP, 2023	REVISED BY: KEW	DRAWN BY: MDK
FILENAME: Grand Rapids.dwg	LAYOUT NAME/NUMBER: PCI	FIGURE: 6	

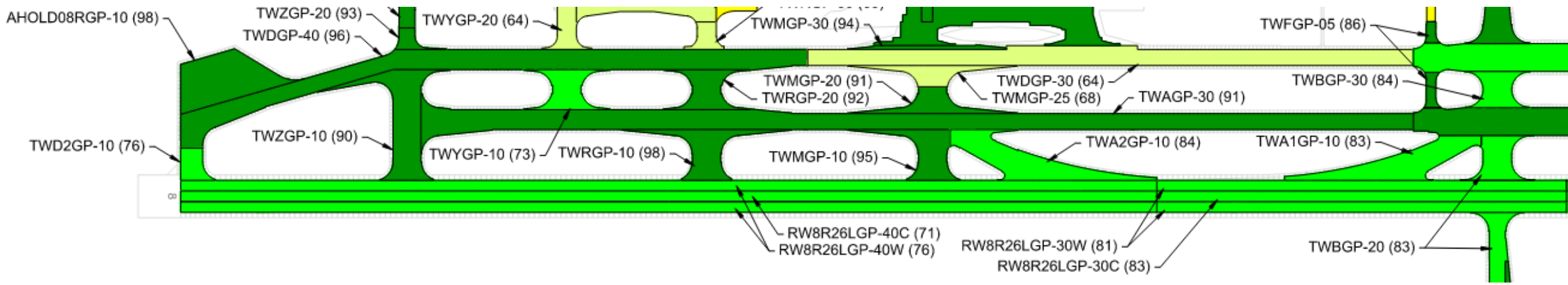

• Runway 8R/26L:

- Lowest PCI = 71
- Highest PCI = 83

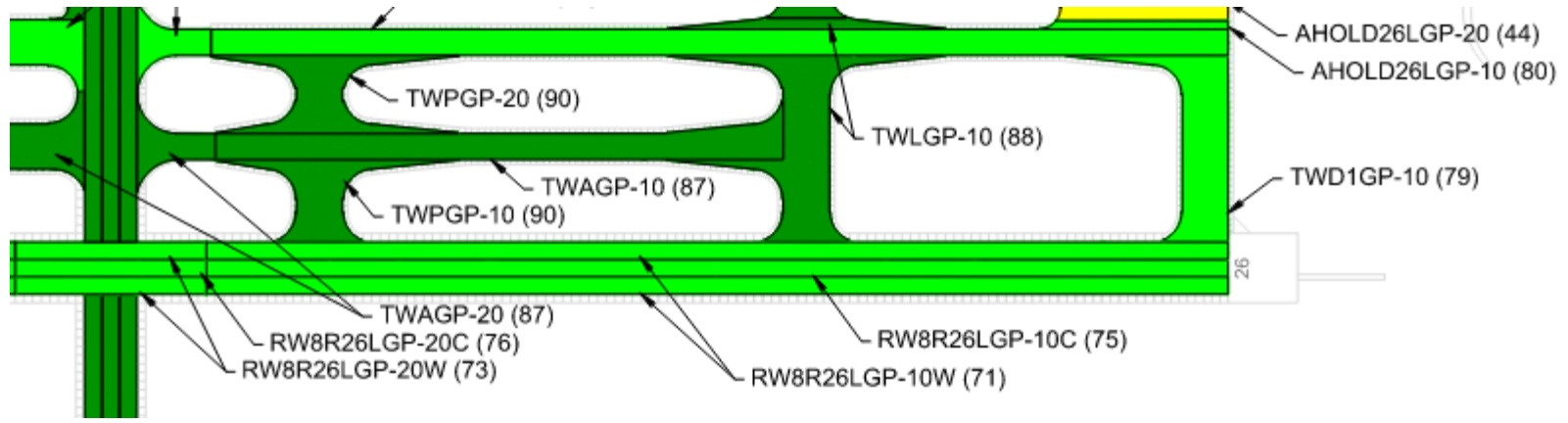

# Runway 8R/26L: 2021 ASR Map

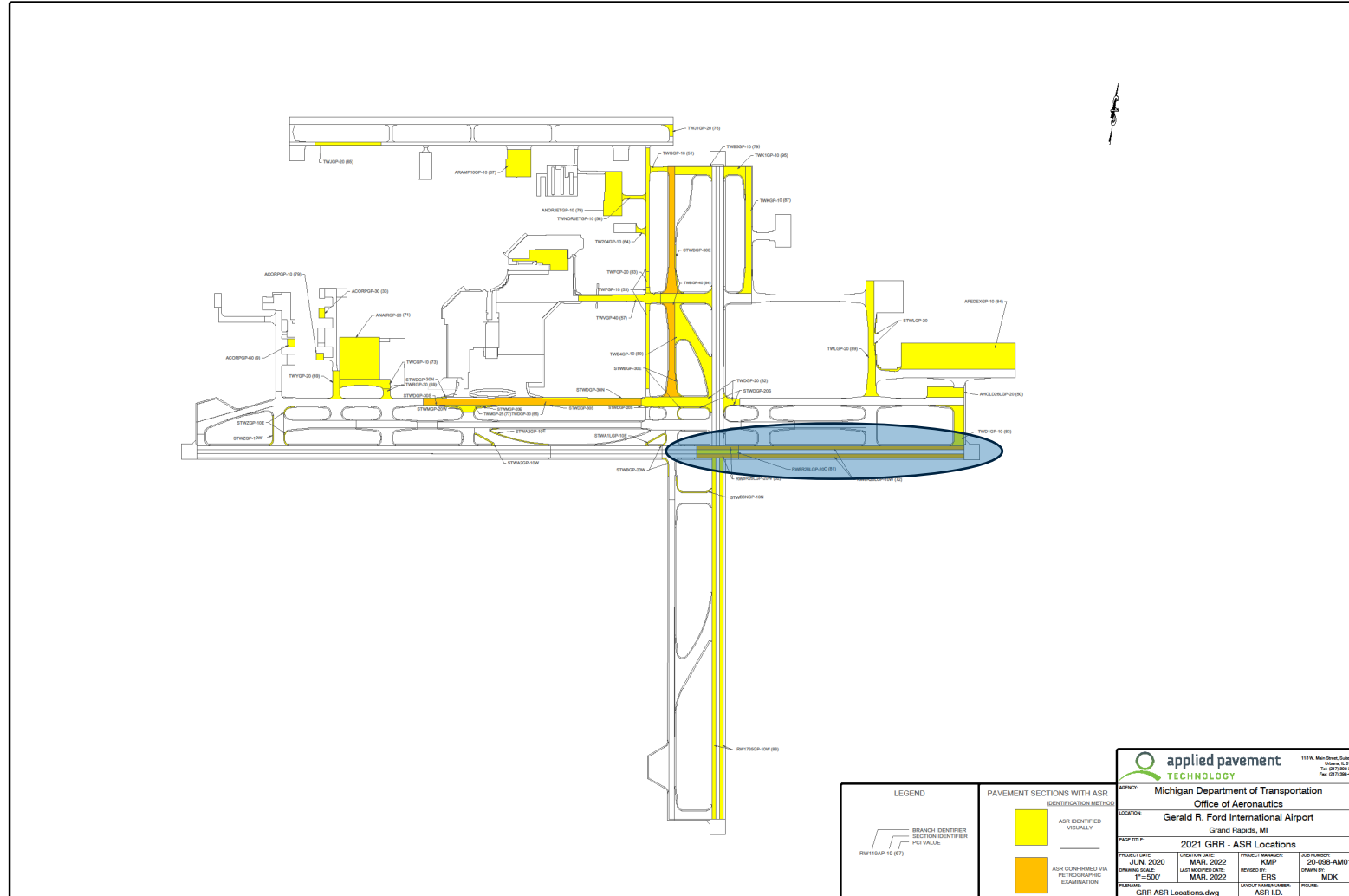

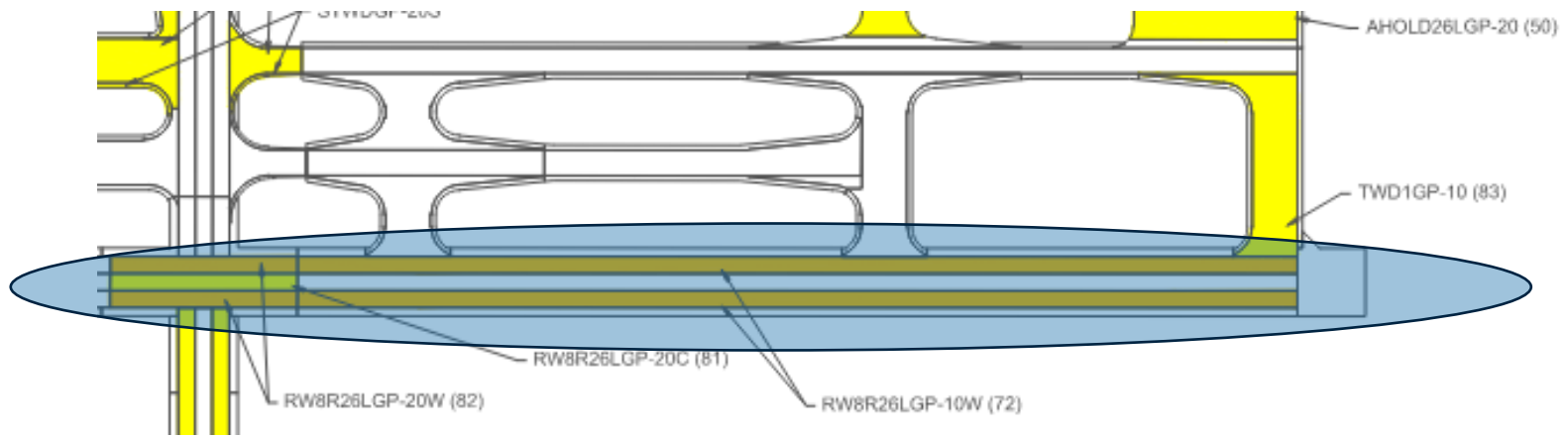
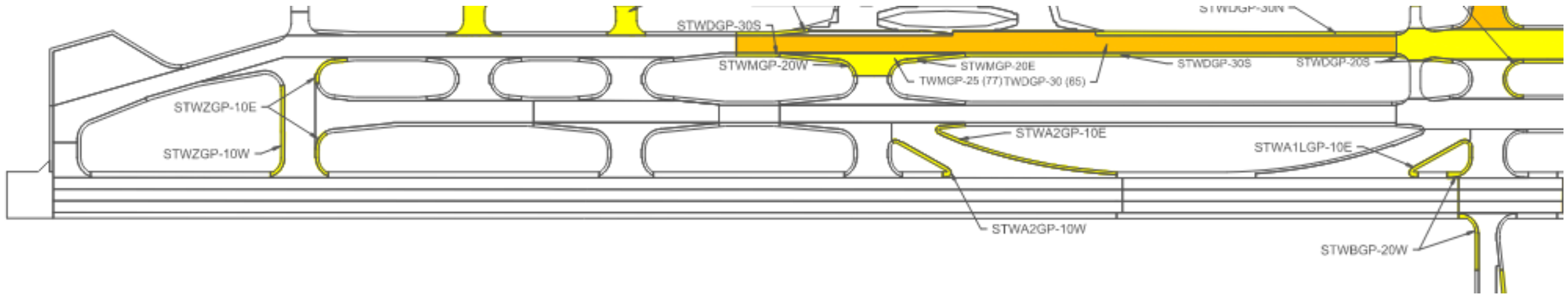



- Runway 8R/26L:
  - 470/R/D/W/T

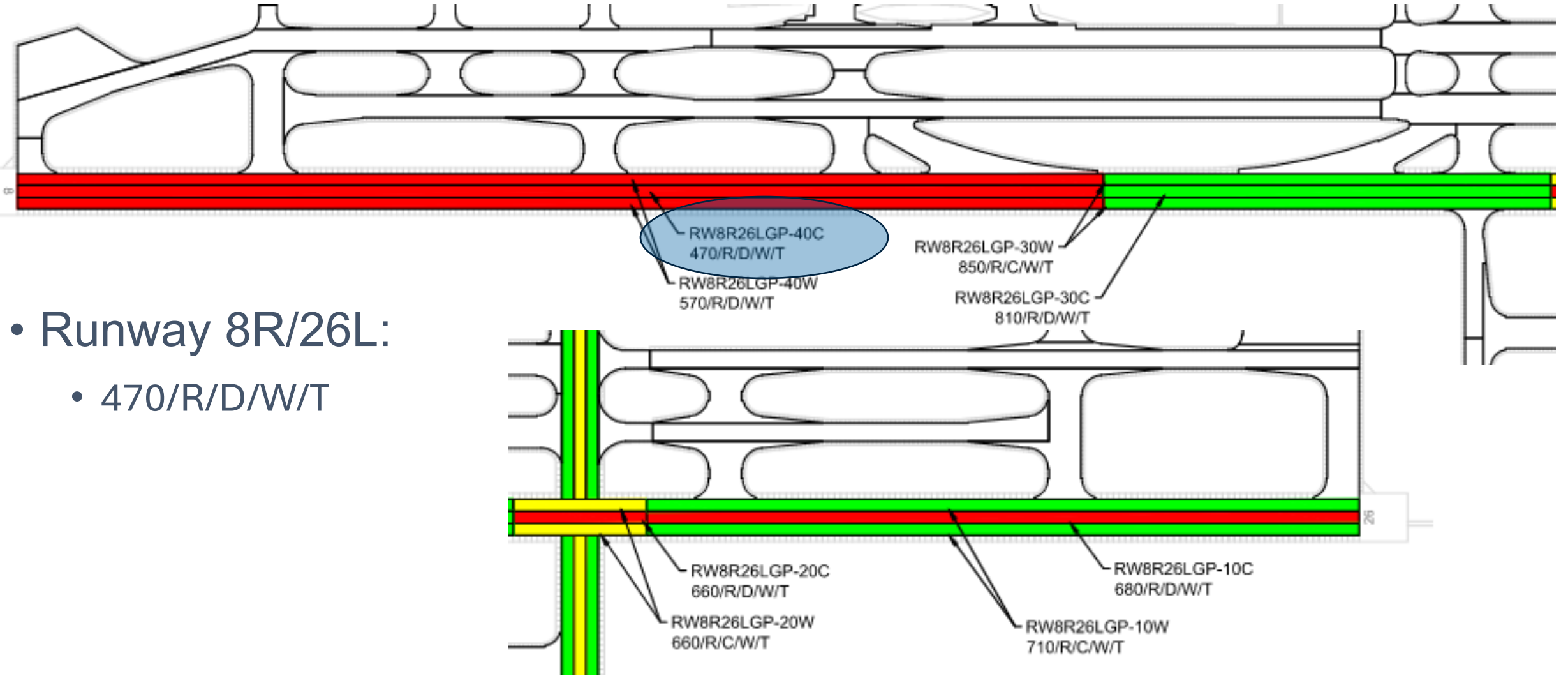

# 2025 - 2029 Capital Plan

GFIAA Board Approval

September 17, 2024



*Where the going gets good.™*

# Runway 8R/26L: Identified Projects



- 2025
  - Airfield Joint/Crack Sealant
  - Rehab Planning – Phasing and Financial Plan
- 2027
  - Runway Intersection Pavement Replacement - Design
- 2028
  - Runway Intersection Pavement Replacement – Construction
  - Runway 8R/26L (East of 17/35) Rehab - Design
- 2029
  - Runway 8R/26L (East of 17/35) Rehab – Construction
  - Runway 8R/26L (West of 17/35) Rehab - Design
- 2030
  - Runway 8R/26L (West of 17/35) Rehab - Construction



# Airfield & AIP Funding

Funding Focus:

Airport Improvement Program

Airport Improvement Grants

FAA Supplemental Funding

FAA Discretionary Funding

# Runway 8R/26L Rehabilitation Engineering Services

Request #2518

SOQs due June 5, 2025 – 2:00 pm (local)



*Where the going gets good.™*

**THANK YOU!**



5514

GERALD R.  
**FORD** International  
Airport

*Celebrando 60 años.*

1. On page 6, under Submission Format and Evaluation Criteria, the following instructions are repeated:

*“State the full name and address of the organization and, if applicable, the branch office, consultants, or other subordinate elements that will provide or assist in providing the service. Include phone number(s), email address(s) and Respondent’s website address.”*

Does this information need to be included in both the Executive Summary/Business Organization section and the Firm Experience and Qualifications section? Is there any additional information that needs to be included in the Firm Experience and Qualifications section?

- a. **No this information is not required to be duplicated. We would like to see this information somewhere in the proposal to ensure we have a way to contact the respondent. But it is not an evaluated subject matter. Duplications should be removed in Addendum 1.**
2. The RFQ states that the On-Site Conference is voluntary (pg 3 and 4); however, it also notes that “if a firm representative does not sign in prior to the scheduled pre-submission conference, their firm will not be considered.” This creates some ambiguity as to whether attendance is required for interested parties. Could you please clarify this requirement?
  - a. **This comes from the topics mentioned by the GFIAA staff in the Pre-Bid Meeting regarding updating our processes to better suit the FAA’s vision for transparency. The mentioned language is holdover from previous versions of that section. **Attendance to the Pre-Submission Conference was not mandatory. Any interested party is allowed to submit for this solicitation still.****
3. Is there a specific Disadvantaged Business Enterprise (DBE) participation goal established for this project for the professional services? If so are there any forms that need to be filled out for this?
  - a. **The airport has a standard DBE goal of 5% that will be anticipated for this project. No forms are required with phase one of the RFQ.**
4. The federal provisions section in the RFQ appears to be incomplete but we assume this is because it is just a sample of what would be used in future contracts. Please confirm.
  - a. **Yes, the Federal Provisions listed in the solicitation document are only those that are required to be listed in any solicitation using Federal Funding. Any subsequent contract resulting from the solicitation would have it’s own specific Federal Provisions section based upon what the FAA requires, while still adhering to those in the original solicitation.**



**REVISED 5/27/2025**

**REQUEST FOR QUALIFICATIONS**

Runway 8R/26L Rehabilitation Consulting

**REQUEST NUMBER:** 2518

**DUE DATE:** June 5, 2025

**DUE TIME:** 2:00 pm (local)

# Contents

**INTRODUCTION ..... 2**

**SOLICITATION AND PROJECT SCHEDULE ..... 2**

**VOLUNTARY ON-SITE CONFERENCE ..... 2**

**WORK SCOPE ..... 3**

    Existing Condition Assessment and Reporting ..... 3

    Development of Preliminary Design Plans, Phasing Strategy, and Cost Estimates..... 3

    Operational Impact Mitigation and Phasing Considerations ..... 3

    Preliminary Design and Financial Planning Support..... 4

    Final Design, Specifications, and Bidding Support..... 4

    Construction Administration and Closeout Services..... 4

    Grant Support and Funding Assistance..... 4

**CONTRACTURAL EXPECTATIONS ..... 4**

**REQUESTS FOR INFORMATION..... 5**

**SUBMISSION FORMAT AND EVALUATION CRITERIA ..... 5**

    Template Evaluation Matric..... 6

**REQUEST FOR PROPOSAL SUBMISSION ..... 7**

**AIRPORT SECURITY ..... 7**

**TERMS AND CONDITIONS ..... 9**

**MICHIGAN FREEDOM OF INFORMATION ACT ..... 11**

**EVALUATION, STATUS UPDATES/AWARD NOTIFICATION ..... 11**

**FEDERAL PROVISIONS ..... 13**

**EXHIBITS ..... 26**

    Exhibit A – 2023 PCI ..... 26

    Exhibit B – GRR ASR Locations ..... 27

    Exhibit C – Pavement Section Locations with PCRs ..... 28

## INTRODUCTION

The Gerald R. Ford International Airport Authority (GFIAA) is requesting statements of qualifications from interested firms to provide multi-year Preliminary Design, Design Engineering, and Construction Administration services for the Rehabilitation of Runway 8R-26L.

The Gerald R. Ford International Airport is the second busiest airport in Michigan, serving business and leisure travelers with nonstop and connecting flights on eight airlines. The Ford Airport is managed and operated by the Gerald R. Ford International Airport Authority.

GFIAA is seeking a consulting firm for Preliminary Design, Design, and Construction Administration services for the full length, including the intersection of Runway 17-35, rehabilitation of Runway 8R-26L through a 2-part public Qualifications Based Selection (QBS) process which includes an initial qualifications evaluation followed by short list interviews and fee negotiation with the selected firm. This 2-part selection process articulates the GFIAA’s goals and provides openness and consistency so that all qualified firms receive fair consideration.

## SOLICITATION AND PROJECT SCHEDULE

ACTIVITY	DATE
RFQ Issue Date	May 2, 2025
Voluntary On-Site Conference	May 20, 2025
Question Deadline	May 22, 2025
Submission Due Date	June 5, 2025 at 2 pm
Contract Start Date	July 2025

GFIAA reserves the right to modify the deadline set forth in the above table in its sole discretion. Any such modifications will be stated in an addendum.

## VOLUNTARY ON-SITE CONFERENCE

CONFERENCE DETAILS	
Conference Date	May 20, 2025
Conference Time (local)	9 am
Conference Location	International Room 1st floor of the airport terminal building,

	5500 44th St. SE, Grand Rapids, MI 49512
--	--

A voluntary pre-submission conference is scheduled for this request. Equal opportunity will be provided for all Respondents to ask questions.

Attendees should arrive a minimum of five (5) minutes before the scheduled date and time. Attendees will not be allowed to sign in after the conference has commenced. ~~If a firm representative does not sign in prior to the scheduled pre-submission conference, their firm will not be considered.~~

Attendees requiring special services are asked to provide their requirements to the GFIAA at least forty-eight (48) hours in advance to allow for accommodations.

A voluntary on-site tour will be offered to all attendees following the conclusion of the meeting.

## WORK SCOPE

The Scope of Services outlined below, as may be modified through negotiation and/or by written addendum issued by the Airport Authority, will be incorporated into the final Agreement with the selected Consultant. The selected Consultant will be expected to provide a full range of professional engineering, pre-design, design, construction, and grant support services related to the rehabilitation of Runway 8R/26L. These services will be delivered in accordance with all applicable Federal Aviation Administration (FAA), state, and local regulations, guidelines, and best practices.

### Existing Condition Assessment and Reporting

- Conduct a comprehensive field inspection and evaluation of the existing pavement structure, drainage infrastructure, and other related components of Runway 8R/26L.
- Perform non-destructive testing and core sampling as needed to evaluate pavement condition and subgrade integrity.
- Document findings in a detailed Existing Conditions Report, including photographic evidence, engineering assessments, and recommendations for rehabilitation or reconstruction strategies.
- Identify any deficiencies affecting operational safety or long-term serviceability.

### Development of Preliminary Design Plans, Phasing Strategy, and Cost Estimates

- Prepare preliminary engineering plans showing proposed improvement concepts for Runway 8R/26L.
- Develop a phased implementation strategy designed to minimize operational disruptions and maintain compliance with FAA and airport operational requirements.
- Provide conceptual-level cost estimates, broken down by phase, to support budgeting and planning.
- Coordinate with airport staff to prioritize improvements based on operational needs and funding availability.

### Operational Impact Mitigation and Phasing Considerations

- Design a project phasing approach that ensures minimal to no disruption to daily airport operations, with particular attention to maintaining airfield access and aircraft movement.
- Collaborate with Airport Operations, FAA Air Traffic Control, and other stakeholders to develop and vet phased construction scenarios.

- Include temporary traffic control plans, safety management strategies, and night or off-peak construction options as appropriate.

### Preliminary Design and Financial Planning Support

- Advance selected alternatives through preliminary design, incorporating stakeholder feedback and technical considerations.
- Analyze and recommend the most cost-effective and technically feasible rehabilitation, or reconstruction, method, including eligibility for FAA Airport Improvement Program (AIP) or other funding.
- Assist in refining the project's financial plan, including lifecycle cost analysis and prioritization of eligible and ineligible items under FAA funding criteria.
- Facilitate coordination meetings with FAA and airport staff to define final project scope.

### Final Design, Specifications, and Bidding Support

- Develop full construction documents, including detailed design drawings, technical specifications, bid item descriptions, and engineer's estimates.
- Ensure all plans meet FAA standards, including AC 150/5370 series and other applicable design circulars.
- Assist with bid phase services, including responding to contractor inquiries, issuing addenda, attending pre-bid meetings, and evaluating bids for compliance and responsiveness.

### Construction Administration and Closeout Services

- Provide construction phase services including full-time or part-time resident inspection, materials testing, submittal review, and quality assurance monitoring.
- Oversee contract administration functions, such as pay application reviews, change order evaluations, and schedule tracking.
- Maintain communication with contractors, airport staff, and FAA throughout the construction period to ensure adherence to scope, budget, and schedule.
- Prepare and deliver complete as-built drawings and final project documentation in both hard copy and digital formats as required by the Airport Authority and FAA.

### Grant Support and Funding Assistance

- Identify eligible state and federal funding sources applicable to the project, including FAA AIP grants, state aviation grants, and other potential opportunities.
- Prepare or support preparation of grant applications, project justification narratives, and supplemental documentation required for funding submittals.
- Assist the Airport Authority in meeting all grant-related reporting and compliance requirements throughout the project lifecycle.
- Coordinate with FAA on reimbursement requests, project closeout procedures, and documentation audits.

## CONTRACTURAL EXPECTATIONS

GFIAA anticipates utilizing the Michigan Department of Transportation Office of Aeronautics (MDOT-AERO) standard consultant contract as a basis for the consultant contract resulting from this selection. Contract documents will be outlined in part 2 of this selection process which will be issued to short listed firms. Federal regulations related to the use of federal funding will be incorporated into the contract.

Consultants are encouraged to include Disadvantaged Business Enterprise (DBE) firms in their submittal including those certified via the Michigan Department of Transportation Michigan Unified Certification Program (MUCP).

## REQUESTS FOR INFORMATION

Questions regarding this solicitation are to be submitted in writing to [purchasing@grr.org](mailto:purchasing@grr.org) prior to 2 p.m. on May 22, 2025.

GFIAA reserves the right to publish and respond to an inquiry, respond directly to the inquirer without publishing or not respond to the inquiry at its sole discretion. Unless otherwise indicated, all questions will be compiled into one document and answers will be issued as a Questions & Answers document within 4 days after the question deadline.

It is the firm's responsibility to become familiar with and fully informed regarding the terms, conditions, and specifications of this solicitation. Lack of understanding or misinterpretation of any portions of this solicitation shall not be cause for withdrawal after opening or for subsequent protest of award.

Addendums will only be published by the GFIAA Purchasing Department and available for review at [www.grr.org](http://www.grr.org).

## SUBMISSION FORMAT AND EVALUATION CRITERIA

Submissions should include and will be evaluated on the elements in weighted categories out of 100 points outlined below:

### **PART 1 – Solicitation Phase – 100 Points**

#### **Executive Summary and Business Organization (0 points) – Two (2) pages maximum**

Summarize the Respondent's strong points and how experience, particularly with similar responsibilities, will benefit the stakeholders. State the full name and address of the organization and, if applicable, the branch office, consultants, or other subordinate elements that will provide or assist in providing the service. **Include phone number(s), email address(s) and Respondent's website address.**

#### **Firm Experience and Qualifications (25 points) – One (1) page maximum**

Respondents shall provide a brief summary of the **firm's** relevant experience and qualifications as it pertains to the scope of this project. This section should demonstrate the firm's capabilities, technical expertise, and history of successfully completing comparable work. (Not to be confused with the "References" section below)

#### **Understanding of Federal Provisions (10 points) – Two (2) pages maximum**

The Respondent's understanding and experience with federal provisions, including compliance with FAA regulations, environmental requirements, and other applicable federal laws, will be a key consideration in the evaluation process. Additionally, Respondents must demonstrate their ability to effectively communicate and coordinate with the local FAA Airport District Office (ADO) to ensure alignment with federal guidelines and local airport needs.

#### **Approach and Methodology (25 points) – Twelve (12) pages maximum**

State in succinct terms the Respondent’s understanding of the major issues of this request. Describe specifically the Respondent’s intended process and responsibilities. Identify important steps that will be taken to meet the GFIAA’s expectations and identify deliverables. Respondent should also show experience with pavement reconstruction if rehabilitation is not the determined method of improvement.

**Key Personnel and Project Team (30 points) – No Page Limit**

Provide a chart with the staff you are committing to the project. Show lines of authority and communication, and provide a brief role description, responsibilities and availability for each person as they relate to the project. The respondent shall demonstrate both technical knowledge and project management abilities. In addition to representing team members’ experience, the team’s approach to defining and managing projects, including coordination with the Airport through project closeout, should be demonstrated. Attach resumes of all personnel in GSA SF-330 Part 1 format.

**References (10 points) – Three (3) pages maximum**

Provide a minimum of three (3) relevant references, preferably for projects of similar scope and complexity. Include the names of the projects, location, completion date, project cost, and specific challenges; identify project team members and references for each project including telephone numbers and email addresses.

***PART 2 – Interview Phase (Shortlisted Firms Only) – 25 Points***

**Firm Interview (25 points)**

Shortlisted firms will be invited to participate in an interview as part of the final selection process. The interview will provide an opportunity for the selection committee to further evaluate each firm’s project understanding, team qualifications, and approach, as well as to ask clarifying questions related to the submitted proposal.

Template Evaluation Matrix

**125 Points Total (100 for Response, additional 25 possible for interview phase)**

<b>Evaluation Criteria</b>	<b>Maximum Points</b>	<b>Score</b>	<b>Comments</b>
Executive Summary	0	N/A	Not Scored
Firm Experience and Qualifications	25		
Understanding of Federal Provisions	10		
Approach and Methodology	25		
Key Personnel and Project Team	30		
References	10		
<b>Total Points</b>	<b>100</b>		
Interview (Shortlist Firms Only)	25		

---

**Total – Response & Interview****125**

## REQUEST FOR PROPOSAL SUBMISSION

Responses may be delivered physically or electronically. To be considered, complete submissions must be received prior to the due date and time specified (local time).

- Hard copy responses can be mailed or otherwise delivered to the address below.

Submission address:

Attn: AJ Nye, Procurement Specialist

Gerald R Ford International Airport Authority

5500 44<sup>th</sup> St SE

Grand Rapids, MI 49512

- Electronic responses can be securely uploaded as a single pdf document to:

<https://www.dropbox.com/request/f4hoTpMdnwXu1nEGWhI>

Electronic submissions shall be named with a form or portion of the firm's name as part of the document name.

The firm certifies the response submitted has not been made or prepared in collusion with any other respondent and the prices, terms or conditions thereof have not been communicated by or on behalf of the respondent to any other respondent prior to the official opening of this request. This certification may be treated for all purposes as if it were a sworn statement made under oath, subject to the penalties for perjury. Moreover, it is made subject to the provisions of 18 U.S.C. Section 1001, relating to the making of false statements.

Submissions may be withdrawn by written request only if the request is received on or before the opening date and time.

Submissions not meeting these criteria may be deemed non-responsive.

GFIAA is not liable for any costs incurred by any prospective firm prior to the awarding of a contract, including any costs incurred in addressing this solicitation.

## AIRPORT SECURITY

It is essential that during the performance of this contract that airport security be maintained and that operations under this agreement conform to Airport security requirements.

### Airport-Issued Identification Badges -

Identification badges are issued by the Airport Police Department to provide unescorted access to authorized employees performing job duties within the airport. Contractors assigned to this account must be badged to provide services within the Secure Area. GRFIAA will not provide escort. The Contractor assumes responsibility for the conduct of all personnel working on airport property. All personnel within the Secured Area must display an airport-issued identification badge or be escorted by personnel with a badge who has been granted escort privileges. Identification badges must be worn on an individual's outermost garment and above the waist at all times.

The Airport encourages all Contractor personnel to be badged. **An unbadged person is to be under escort at all times.** This will be strictly enforced.

Badges are the property of the Airport and must be returned promptly upon fulfillment of this agreement, an individual's termination or at the request of the GRFIAA. Failure to return badges may result in the Contractor being declared nonresponsive and ineligible for future Airport contracts.

### Pre-Badging Requirements for General Contractor -

Contractor should coordinate badge requirements with the Airport Project Manager. DO NOT WAIT UNTIL THE LAST MINUTE. The following documents are required before the Contractor begin the badging process for themselves, their subcontractors or their employees:

1. Project Letter from Contractor – Letter must include the Project Name with Start Date and estimated End Date, PLUS a list of all Subcontractors (if any).
2. Authorized Signer Letter(s) – Contractors/subcontractors will designate one or more individuals to be Authorized Signers for badge enrollments. The Authorized Signer letter must be on company letterhead. An Authorized Signer must obtain an airport badge prior to attending signatory training which is administered by the Airport Security Coordinator. The badging process is outlined below.

### Badging Process –

The badging process requires two visits to the Airport Police office for each applicant.

#### 1. Badge Application and Background Checks

The process is initiated with the Authorized Signatory. They will be enrolling the applicant in the airport's SAFE Signatory Portal. Once enrolled and submitted, each applicant must make an initial appointment with the airport badging office. ([www.grrbadging.as.me](http://www.grrbadging.as.me))

As outlined in the appointment information, each individual is required to provide 2 pieces of acceptable ID, as well as provide a completed GRR Fingerprint Application. Information about acceptable IDs and the GRR Fingerprint Application can be found on the badging services page: <http://www.grr.org/badging-services.php>

The airport will perform two background checks on the applicant:

- a. A security threat assessment (STA) is a name verification background check conducted by the Transportation Security Administration (TSA).

b. A criminal history records check (CHRC) is a fingerprint-based background check to determine if personnel have been convicted of a felony within the last ten (10) years. Background check results can take anywhere from two days to two weeks to be completed.

The Contractor's Authorized Signatory will be notified once the background checks have been completed and approved. The Authorized Signatory will notify the individual and have them schedule their assigned appointment for Badge Training and Issuance.

## 2. Training and Badge Issuance

The applicant will make an appointment at [www.grrbadging.as.me](http://www.grrbadging.as.me) for their assigned training and badge issuance. Training may include the following depending on which privileges the Authorized Signatory assigned during enrollment:

- a. SIDA training
- b. Non-movement driver's training

Each training takes approximately 45 minutes to complete. Once completed and passed, the individual will receive their ID.

Training/Badging must be completed within 30 days from date of approval. Applicants who fail to complete badging within the allotted time will be assessed a resubmission fee.

## 3. Authorized Signatory Training (IF APPLICABLE)

If an individual will be designated as an Authorized Signatory for their company, they will need to schedule an appointment for Authorized Signatory Training with the Airport Security Coordinator. This is typically handled through communication with the original Authorized Signatory and can only be completed after they have received their badge.

All initial badging fees will be at no cost to the Contractor. If an ID badge is lost, stolen, or otherwise unaccounted for immediate notify Airport Communications at 616.233.6055. The ID badge replacement fee is \$50.00. The badge holder is responsible for the ID badge replacement fee.

## TERMS AND CONDITIONS

GFIAA reserves the right to require that its standard terms and conditions apply to any actual order placed in response to a firm's submission. No attempt to modify GFIAA's Standard Terms and Conditions shall be binding, absent agreement on such modification in writing and signed by GFIAA.

No payment shall be made to the Respondent for any extra material or services, or of any greater amount of money than stipulated to be paid in the contract, unless changes in or additions to the contract requiring additional outlay by the Respondent shall first have been expressly authorized and ordered in writing by contract amendment or otherwise furnished by the GFIAA.

The intent of these specifications is to solicit a properly designed and all-inclusive response. Any requirements not in the specifications, but which are needed for such a response, are to be included in the submission.

The Gerald R Ford International Airport Authority, in accordance with the provisions of Title VI of the Civil Rights Act of 1964 (78 Stat. 252, 42 USC §§ 2000d to 2000d-4) and the Regulations, hereby notifies all bidders or offerors that it will affirmatively ensure that for any contract entered into pursuant to this advertisement, [select businesses, or disadvantaged business enterprises or airport concession disadvantaged business enterprises] will be afforded full and fair opportunity to submit bids in response to this invitation and no businesses will be discriminated against on the grounds of race, color, national origin (including limited English proficiency), creed, sex (including sexual orientation and gender identity), age, or disability in consideration for an award.

The Respondent shall not discriminate against an employee or applicant for employment with respect to hire, tenure, terms, conditions or privileges of employment, or a matter directly or indirectly related to employment, because of race, color, religion, national origin, age, sex, height, weight, marital status, or disability that is unrelated to the individual's ability to perform the duties of a particular job or position.

The Respondent shall observe and comply with all applicable federal, state, and local laws, ordinances, rules and regulations at all times during the completion of any contract with the GFIAA.

The terms of this request shall be interpreted, construed and enforced pursuant to the laws of the State of Michigan, and the Parties irrevocably consent to the jurisdiction of the federal and state courts presiding in Michigan.

The GFIAA is tax-exempt and a regional airport authority organized under 2015 P.A. 95, being MCL 259.137 et. seq.

**Vendor Representation and Warranty Regarding Federal Excluded Parties List:** The Respondent acknowledges that the GFIAA may be receiving funds from or through the Federal Government; such funds may not be used to pay any Respondent on the Federal Excluded Parties List (EPLS). The Respondent represents and warrants to the GFIAA that it is not on the Federal EPLS. If the Respondent is in non-compliance at any time during execution or term of this agreement (including any extensions thereof), the Respondent shall be in breach and the GFIAA shall be entitled to all remedies available to it at law or equity, specifically including but not limited to recovery of all moneys paid to the Respondent, all consequential damages (including the loss of grant funding or the requirement that grant funding be returned), and attorney fees (including the costs of in-house counsel) sustained as a result of the Respondent's non-compliance with this warranty and representation.

Pursuant to the Michigan Iran Economic Sanctions Act, 2012 P.A. 517, by submitting a bid, proposal or response, Respondent certifies, under civil penalty for false certification, that it is fully eligible to do so under law and that it is not an "Iran linked business," as that term is defined in the Act.

Insurance requirements are posted on the Documents and Forms page of the GFIAA website within the Purchasing Terms and Conditions document.

**Termination For Cause:** Should the firm fail to perform the Work as required by and in accordance with the schedule or time requirements, or otherwise violate any of the terms set forth in the Solicitation Request, it shall constitute breach of the Contract. Other than in force majeure situations, Respondent shall have five (5) calendar days to cure a breach of the Contract (the "Cure Period") following issuance of GFIAA written notice. Failure to cure a breach of the

Contract within said Cure Period shall allow the GFIAA to, without further notice to the Respondent, declare the Contract terminated and proceed with the replacement of the Respondent and the GFIAA shall be entitled to all remedies available to it at law or in equity including a claim against any required payment/performance bonds.

Termination Without Cause: Notwithstanding any other provision, at any time and without cause, GFIAA shall have the right, in its sole discretion, to terminate the contract by giving sixty (60) days written notice.

Although it is the intent to contract with one provider, the GFIAA reserves the right to contract with alternate sources if the Respondent is unable or unwilling to service its obligation, or it is deemed by GFIAA to be in its best interest to use alternate sources.

Assignment: Neither party shall assign or delegate any of its rights or obligations under this Agreement without the prior written consent of the other party.

Respondent warrants that they are an authorized provider of products or services of his/her submission.

## **MICHIGAN FREEDOM OF INFORMATION ACT**

Information submitted in this solicitation is subject to the Michigan Freedom of Information Act and may not be held in confidence after the Respondent's submission is opened. A submission will be available for review after the project has been awarded.

GFIAA cannot assure that all of the information submitted as part of or peripheral to the Respondent's submission will be kept confidential. Any Respondent submission language designated as confidential is considered automatically invalid and void. GFIAA is subject to the Michigan Freedom of Information Act, which prohibits it from concealing information on or associated with responses, successful or unsuccessful, once they are opened.

## **EVALUATION, STATUS UPDATES/AWARD NOTIFICATION**

The Authority reserves the right to request additional information it may deem necessary after the submissions are received.

As part of the evaluation process, Respondents may be requested to make an oral presentation, at the Respondent's expense, to an evaluation committee. Key staff to be assigned to this project must participate in this presentation unless otherwise waived by the Authority. The presentation may be followed by a question-and-answer session.

The Authority reserves the right at its discretion to waive irregularities of this solicitation process.

In the event of extension errors, the unit price shall prevail and the Respondent's total offer will be corrected accordingly. In the event of addition errors, the extended totals will prevail and the Respondent's total will be corrected accordingly. Respondent must check their submission where applicable. Failure to do so will be at the Respondent's risk. Submissions having erasures or corrections must be initialed in ink by the Respondent. Respondents are cautioned to recheck their submissions for possible errors.

The Respondent shall not be allowed to take advantage of error, omissions or discrepancies in the specifications.

The Authority, at its sole discretion, reserves the right to award to the Respondent whose response is deemed most advantageous to the Authority. The Authority, at its sole discretion, shall select the most responsive and responsible Respondent and evaluate all responses based on the requirements and criterion set forth in this solicitation while reserving the right to weigh specifications and other factors in the award. The Authority reserves the right to reject any and all submissions as a result of this solicitation.

The Authority reserves the right to award by line item when applicable and to accept or reject any or all parts of a submission.

Accelerated discounts should be so stated at the time of submission. If quick-pay discounts are offered, The Authority reserves the right to include that discount as part of the award criterion. Prices must, however, be based upon payment in thirty (30) days after receipt, inspection, and acceptance. In all cases, quick-pay discounts will be calculated from the date of the invoice or the date of acceptance, whichever is later.

Award notifications are posted on the Authority website. It is the Respondent's responsibility to monitor the website for status updates.

## FEDERAL PROVISIONS

### NOTICE OF REQUIREMENT FOR AFFIRMATIVE ACTION TO ENSURE EQUAL EMPLOYMENT OPPORTUNITY

1. The Offeror's or Bidder's attention is called to the "Equal Opportunity Clause" and the "Standard Federal Equal Employment Opportunity Construction Contract Specifications" set forth herein.
2. The goals and timetables for minority and female participation, expressed in percentage terms for the Contractor's aggregate workforce in each trade on all construction work in the covered area, are as follows:

#### Timetables

Goals for minority participation for each trade: **[Sponsor must insert established goal]**

Goals for female participation in each trade: 6.9%

These goals are applicable to all of the Contractor's construction work (whether or not it is Federal or federally assisted) performed in the covered area. If the Contractor performs construction work in a geographical area located outside of the covered area, it shall apply the goals established for such geographical area where the work is actually performed. With regard to this second area, the Contractor also is subject to the goals for both its federally involved and nonfederally involved construction.

The Contractor's compliance with the Executive Order and the regulations in 41 CFR Part 60-4 shall be based on its implementation of the Equal Opportunity Clause, specific affirmative action obligations required by the specifications set forth in 41 CFR 60-4.3(a) and its efforts to meet the goals. The hours of minority and female employment and training must be substantially uniform throughout the length of the contract, and in each trade, and the Contractor shall make a good faith effort to employ minorities and women evenly on each of its projects. The transfer of minority or female employees or trainees from Contractor to Contractor or from project to project for the sole purpose of meeting the Contractor's goals shall be a violation of the contract, the Executive Order and the regulations in 41 CFR Part 60-4. Compliance with the goals will be measured against the total work hours performed.

3. The Contractor shall provide written notification to the Director of the Office of Federal Contract Compliance Programs (OFCCP) within 10 working days of award of any construction subcontract in excess of \$10,000 at any tier for construction work under the contract resulting from this solicitation. The notification shall list the name, address, and telephone number of the subcontractor; employer identification number of the subcontractor; estimated dollar amount of the subcontract; estimated starting and completion dates of the subcontract; and the geographical area in which the subcontract is to be performed.

4. As used in this notice and in the contract resulting from this solicitation, the "covered area" is **[Sponsor must insert state, county, and city]**.

## FAA BUY AMERICAN PREFERENCE

The Contractor certifies that its bid/offer is in compliance with 49 USC § 50101, BABA and other related Made in America Laws,<sup>1</sup> U.S. statutes, guidance, and FAA policies, which provide that Federal funds may not be obligated unless all iron, steel and manufactured goods used in AIP funded projects are produced in the United States, unless the Federal Aviation Administration has issued a waiver for the product; the product is listed as an Excepted Article, Material Or Supply in Federal Acquisition Regulation subpart 25.108; or is included in the FAA Nationwide Buy American Waivers Issued list.

The bidder or offeror must complete and submit the certification of compliance with FAA's Buy American Preference, BABA and Made in America laws included herein with their bid or offer. The Airport Sponsor/Owner will reject as nonresponsive any bid or offer that does not include a completed certification of compliance with FAA's Buy American Preference and BABA.

The bidder or offeror certifies that all constructions materials, defined to mean an article, material, or supply other than an item of primarily iron or steel; a manufactured product; cement and cementitious materials; aggregates such as stone, sand, or gravel; or aggregate binding agents or additives that are or consist primarily of: non-ferrous metals; plastic and polymer-based products (including polyvinylchloride, composite building materials, and polymers used in fiber optic cables); glass (including optic glass); lumber; or drywall used in the project are manufactured in the U.S.

---

<sup>1</sup> Per Executive Order 14005 "Made in America Laws" means all statutes, regulations, rules, and Executive Orders relating to federal financial assistance awards or federal procurement, including those that refer to "Buy America" or "Buy American," that require, or provide a preference for, the purchase or acquisition of goods, products, or materials produced in the United States, including iron, steel, and manufactured products offered in the United States.

## Title VI Solicitation Notice:

The (**Name of Sponsor**), in accordance with the provisions of Title VI of the Civil Rights Act of 1964 (78 Stat. 252, 42 USC §§ 2000d to 2000d-4) and the Regulations, hereby notifies all bidders or offerors that it will affirmatively ensure that for any contract entered into pursuant to this advertisement, [select businesses, or disadvantaged business enterprises or airport concession disadvantaged business enterprises] will be afforded full and fair opportunity to submit bids in response to this invitation and no businesses will be discriminated against on the grounds of race, color, national origin (including limited English proficiency), creed, sex (including sexual orientation and gender identity), age, or disability in consideration for an award.

### Title VI List of Pertinent Nondiscrimination Acts and Authorities

During the performance of this contract, the Contractor, for itself, its assignees, and successors in interest (hereinafter referred to as the “Contractor”) agrees to comply with the following non-discrimination statutes and authorities; including but not limited to:

- Title VI of the Civil Rights Act of 1964 (42 USC § 2000d *et seq.*, 78 stat. 252) (prohibits discrimination on the basis of race, color, national origin);
- 49 CFR part 21 (Non-discrimination in Federally-Assisted programs of the Department of Transportation—Effectuation of Title VI of the Civil Rights Act of 1964);
- The Uniform Relocation Assistance and Real Property Acquisition Policies Act of 1970, (42 USC § 4601) (prohibits unfair treatment of persons displaced or whose property has been acquired because of Federal or Federal-aid programs and projects);
- Section 504 of the Rehabilitation Act of 1973 (29 USC § 794 *et seq.*), as amended (prohibits discrimination on the basis of disability); and 49 CFR part 27 (Nondiscrimination on the Basis of Disability in Programs or Activities Receiving Federal Financial Assistance);
- The Age Discrimination Act of 1975, as amended (42 USC § 6101 *et seq.*) (prohibits discrimination on the basis of age);
- Airport and Airway Improvement Act of 1982 (49 USC § 47123), as amended (prohibits discrimination based on race, creed, color, national origin, or sex);
- The Civil Rights Restoration Act of 1987 (PL 100-259) (broadened the scope, coverage and applicability of Title VI of the Civil Rights Act of 1964, the Age Discrimination Act of 1975 and Section 504 of the Rehabilitation Act of 1973, by expanding the definition of the terms “programs or activities” to include all of the programs or activities of the Federal-aid recipients, sub-recipients and contractors, whether such programs or activities are Federally funded or not);
- Titles II and III of the Americans with Disabilities Act of 1990 (42 USC § 12101, *et seq*) (prohibit discrimination on the basis of disability in the operation of public entities, public and private transportation systems, places of public accommodation, and certain testing entities) as implemented by U.S. Department of Transportation regulations at 49 CFR parts 37 and 38;
- The Federal Aviation Administration’s Nondiscrimination statute (49 USC § 47123) (prohibits discrimination on the basis of race, color, national origin, and sex);
- Executive Order 12898, Federal Actions to Address Environmental Justice in Minority Populations and Low-Income Populations (ensures nondiscrimination against minority populations by discouraging programs, policies, and activities with disproportionately high and adverse human health or environmental effects on minority and low-income populations);
- Executive Order 13166, Improving Access to Services for Persons with Limited English Proficiency, and resulting agency guidance, national origin discrimination includes discrimination because of limited English proficiency (LEP). To ensure compliance with Title VI, you must take reasonable steps to ensure that LEP persons have meaningful access to your programs [70 Fed. Reg. 74087 (2005)];

- Title IX of the Education Amendments of 1972, as amended, which prohibits you from discriminating because of sex in education programs or activities (20 USC § 1681, et seq).

## DAVIS-BACON REQUIREMENTS

### 1. Minimum Wages.

(i) All laborers and mechanics employed or working upon the site of the work will be paid unconditionally and not less often than once a week, and without subsequent deduction or rebate on any account (except such payroll deductions as are permitted by the Secretary of Labor under the Copeland Act (29 CFR Part 3)), the full amount of wages and bona fide fringe benefits (or cash equivalent thereof) due at time of payment computed at rates not less than those contained in the wage determination of the Secretary of Labor which is attached hereto and made a part hereof, regardless of any contractual relationship which may be alleged to exist between the Contractor and such laborers and mechanics.

Contributions made or costs reasonably anticipated for bona fide fringe benefits under section 1(b)(2) of the Davis-Bacon Act on behalf of laborers or mechanics are considered wages paid to such laborers or mechanics, subject to the provisions of paragraph (1)(iv) of this section; also, regular contributions made or costs incurred for more than a weekly period (but not less often than quarterly) under plans, funds, or programs which cover the particular weekly period, are deemed to be constructively made or incurred during such weekly period. Such laborers and mechanics shall be paid the appropriate wage rate and fringe benefits on the wage determination for the classification of work actually performed, without regard to skill, except as provided in 29 CFR § 5.5(a)(4). Laborers or mechanics performing work in more than one classification may be compensated at the rate specified for each classification for the time actually worked therein: *Provided*, that the employer's payroll records accurately set forth the time spent in each classification in which work is performed. The wage determination (including any additional classification and wage rates conformed under (1)(ii) of this section) and the Davis-Bacon poster (WH-1321) shall be posted at all times by the Contractor and its subcontractors at the site of the work in a prominent and accessible place where it can easily be seen by the workers.

(ii)(A) The contracting officer shall require that any class of laborers or mechanics, including helpers, which is not listed in the wage determination and which is to be employed under the contract shall be classified in conformance with the wage determination. The contracting officer shall approve an additional classification and wage rate and fringe benefits therefore only when the following criteria have been met:

- (1) The work to be performed by the classification requested is not performed by a classification in the wage determination;
- (2) The classification is utilized in the area by the construction industry; and
- (3) The proposed wage rate, including any bona fide fringe benefits, bears a reasonable relationship to the wage rates contained in the wage determination.

(B) If the Contractor and the laborers and mechanics to be employed in the classification (if known), or their representatives, and the contracting officer agree on the classification and wage rate (including the amount designated for fringe benefits where appropriate), a report of the action taken shall be sent by the contracting officer to the Administrator of the Wage and Hour Division, U.S. Department of Labor, Washington, DC 20210. The Administrator, or an authorized representative, will approve, modify, or disapprove every additional classification action within 30 days of receipt and so advise the contracting officer or will notify the contracting officer within the 30-day period that additional time is necessary.

(C) In the event the Contractor, the laborers, or mechanics to be employed in the classification, or their representatives, and the contracting officer do not agree on the proposed classification and wage rate (including the amount designated for fringe benefits, where appropriate), the contracting officer shall refer the questions, including the views of all

interested parties and the recommendation of the contracting officer, to the Administrator for determination. The Administrator, or an authorized representative, will issue a determination within 30 days of receipt and so advise the contracting officer or will notify the contracting officer within the 30-day period that additional time is necessary.

(D) The wage rate (including fringe benefits where appropriate) determined pursuant to subparagraphs (1)(ii) (B) or (C) of this paragraph, shall be paid to all workers performing work in the classification under this contract from the first day on which work is performed in the classification.

(iii) Whenever the minimum wage rate prescribed in the contract for a class of laborers or mechanics includes a fringe benefit which is not expressed as an hourly rate, the contractor shall either pay the benefit as stated in the wage determination or shall pay another bona fide fringe benefit or an hourly cash equivalent thereof.

(iv) If the Contractor does not make payments to a trustee or other third person, the Contractor may consider as part of the wages of any laborer or mechanic the amount of any costs reasonably anticipated in providing bona fide fringe benefits under a plan or program, *Provided*, that the Secretary of Labor has found, upon the written request of the Contractor, that the applicable standards of the Davis-Bacon Act have been met. The Secretary of Labor may require the Contractor to set aside in a separate account assets for the meeting of obligations under the plan or program.

2. Withholding. The Federal Aviation Administration or the Sponsor shall upon its own action or upon written request of an authorized representative of the Department of Labor withhold or cause to be withheld from the Contractor under this contract or any other Federal contract with the same prime contractor, or any other federally-assisted contract subject to Davis-Bacon prevailing wage requirements, which is held by the same prime contractor, so much of the accrued payments or advances as may be considered necessary to pay laborers and mechanics, including apprentices, trainees, and helpers, employed by the Contractor or any subcontractor the full amount of wages required by the contract. In the event of failure to pay any laborer or mechanic, including any apprentice, trainee, or helper, employed or working on the site of the work, all or part of the wages required by the contract, the Federal Aviation Administration may, after written notice to the Contractor, Sponsor, Applicant, or Owner, take such action as may be necessary to cause the suspension of any further payment, advance, or guarantee of funds until such violations have ceased.

### 3. Payrolls and Basic Records.

(i) Payrolls and basic records relating thereto shall be maintained by the Contractor during the course of the work and preserved for a period of three years thereafter for all laborers and mechanics working at the site of the work. Such records shall contain the name, address, and social security number of each such worker; his or her correct classification; hourly rates of wages paid (including rates of contributions or costs anticipated for bona fide fringe benefits or cash equivalents thereof of the types described in 1(b)(2)(B) of the Davis-Bacon Act); daily and weekly number of hours worked; deductions made; and actual wages paid. Whenever the Secretary of Labor has found under 29 CFR 5.5(a)(1)(iv) that the wages of any laborer or mechanic include the amount of any costs reasonably anticipated in providing benefits under a plan or program described in section 1(b)(2)(B) of the Davis-Bacon Act, the Contractor shall maintain records that show that the commitment to provide such benefits is enforceable, that the plan or program is financially responsible, and that the plan or program has been communicated in writing to the laborers or mechanics affected, and records which show the costs anticipated or the actual costs incurred in providing such benefits. Contractors employing apprentices or trainees under approved programs shall maintain written evidence of the registration of apprenticeship programs and certification of trainee programs, the registration of the apprentices and trainees, and the ratios and wage rates prescribed in the applicable programs.

(ii)(A) The Contractor shall submit weekly for each week in which any contract work is performed a copy of all payrolls to the Federal Aviation Administration if the agency is a party to the contract, but if the agency is not such a party, the Contractor will submit the payrolls to the applicant, Sponsor, or Owner, as the case may be, for transmission to the Federal Aviation Administration. The payrolls submitted shall set out accurately and completely all of the information

required to be maintained under 29 CFR § 5.5(a)(3)(i), except that full social security numbers and home addresses shall not be included on weekly transmittals. Instead the payrolls shall only need to include an individually identifying number for each employee (e.g., the last four digits of the employee's social security number). The required weekly payroll information may be submitted in any form desired. Optional Form WH-347 is available for this purpose from the Wage and Hour Division Web site at <https://www.dol.gov/agencies/whd/government-contracts/construction/payroll-certification> or its successor site. The prime contractor is responsible for the submission of copies of payrolls by all subcontractors. Contractors and subcontractors shall maintain the full social security number and current address of each covered worker and shall provide them upon request to the Federal Aviation Administration if the agency is a party to the contract, but if the agency is not such a party, the Contractor will submit them to the applicant, Sponsor, or Owner, as the case may be, for transmission to the Federal Aviation Administration, the Contractor, or the Wage and Hour Division of the Department of Labor for purposes of an investigation or audit of compliance with prevailing wage requirements. It is not a violation of this section for a prime contractor to require a subcontractor to provide addresses and social security numbers to the prime contractor for its own records, without weekly submission to the sponsoring government agency (or the applicant, Sponsor, or Owner).

(B) Each payroll submitted shall be accompanied by a "Statement of Compliance," signed by the Contractor or subcontractor or his or her agent who pays or supervises the payment of the persons employed under the contract and shall certify the following:

(1) That the payroll for the payroll period contains the information required to be provided under 29 CFR § 5.5(a)(3)(ii), the appropriate information is being maintained under 29 CFR § 5.5 (a)(3)(i), and that such information is correct and complete;

(2) That each laborer and mechanic (including each helper, apprentice, and trainee) employed on the contract during the payroll period has been paid the full weekly wages earned, without rebate, either directly or indirectly, and that no deductions have been made either directly or indirectly from the full wages earned, other than permissible deductions as set forth in Regulations, 29 CFR Part 3;

(3) That each laborer or mechanic has been paid not less than the applicable wage rates and fringe benefits or cash equivalents for the classification of work performed, as specified in the applicable wage determination incorporated into the contract.

(C) The weekly submission of a properly executed certification set forth on the reverse side of Optional Form WH-347 shall satisfy the requirement for submission of the "Statement of Compliance" required by paragraph (3)(ii)(B) of this section.

(D) The falsification of any of the above certifications may subject the Contractor or subcontractor to civil or criminal prosecution under Section 1001 of Title 18 and Section 231 of Title 31 of the United States Code.

(iii) The Contractor or subcontractor shall make the records required under paragraph (3)(i) of this section available for inspection, copying, or transcription by authorized representatives of the Sponsor, the Federal Aviation Administration, or the Department of Labor and shall permit such representatives to interview employees during working hours on the job. If the Contractor or subcontractor fails to submit the required records or to make them available, the Federal agency may, after written notice to the Contractor, Sponsor, applicant, or Owner, take such action as may be necessary to cause the suspension of any further payment, advance, or guarantee of funds. Furthermore, failure to submit the required records upon request or to make such records available may be grounds for debarment action pursuant to 29 CFR § 5.12.

#### 4. Apprentices and Trainees.

(i) Apprentices. Apprentices will be permitted to work at less than the predetermined rate for the work they performed when they are employed pursuant to and individually registered in a bona fide apprenticeship program registered with

the U.S. Department of Labor, Employment and Training Administration, Office of Apprenticeship Training, Employer and Labor Services, or with a State Apprenticeship Agency recognized by the Office, or if a person is employed in his or her first 90 days of probationary employment as an apprentice in such an apprenticeship program, who is not individually registered in the program, but who has been certified by the Office of Apprenticeship Training, Employer and Labor Services or a State Apprenticeship Agency (where appropriate) to be eligible for probationary employment as an apprentice. The allowable ratio of apprentices to journeymen on the job site in any craft classification shall not be greater than the ratio permitted to the contractor as to the entire work force under the registered program. Any worker listed on a payroll at an apprentice wage rate, who is not registered or otherwise employed as stated above, shall be paid not less than the applicable wage rate on the wage determination for the classification of work actually performed. In addition, any apprentice performing work on the job site in excess of the ratio permitted under the registered program shall be paid not less than the applicable wage rate on the wage determination for the work actually performed. Where a contractor is performing construction on a project in a locality other than that in which its program is registered, the ratios and wage rates (expressed in percentages of the journeyman's hourly rate) specified in the Contractor's or subcontractor's registered program shall be observed. Every apprentice must be paid at not less than the rate specified in the registered program for the apprentice's level of progress, expressed as a percentage of the journeymen hourly rate specified in the applicable wage determination. Apprentices shall be paid fringe benefits in accordance with the provisions of the apprenticeship program. If the apprenticeship program does not specify fringe benefits, apprentices must be paid the full amount of fringe benefits listed on the wage determination for the applicable classification. If the Administrator determines that a different practice prevails for the applicable apprentice classification, fringes shall be paid in accordance with that determination. In the event the Office of Apprenticeship Training, Employer and Labor Services, or a State Apprenticeship Agency recognized by the Office, withdraws approval of an apprenticeship program, the Contractor will no longer be permitted to utilize apprentices at less than the applicable predetermined rate for the work performed until an acceptable program is approved.

(ii) Trainees. Except as provided in 29 CFR § 5.16, trainees will not be permitted to work at less than the predetermined rate for the work performed unless they are employed pursuant to and individually registered in a program which has received prior approval, evidenced by formal certification by the U.S. Department of Labor, Employment and Training Administration. The ratio of trainees to journeymen on the job site shall not be greater than permitted under the plan approved by the Employment and Training Administration. Every trainee must be paid at not less than the rate specified in the approved program for the trainee's level of progress, expressed as a percentage of the journeyman hourly rate specified in the applicable wage determination. Trainees shall be paid fringe benefits in accordance with the provisions of the trainee program. If the trainee program does not mention fringe benefits, trainees shall be paid the full amount of fringe benefits listed on the wage determination unless the Administrator of the Wage and Hour Division determines that there is an apprenticeship program associated with the corresponding journeyman wage rate on the wage determination that provides for less than full fringe benefits for apprentices. Any employee listed on the payroll at a trainee rate that is not registered and participating in a training plan approved by the Employment and Training Administration shall be paid not less than the applicable wage rate on the wage determination for the classification of work actually performed. In addition, any trainee performing work on the job site in excess of the ratio permitted under the registered program shall be paid not less than the applicable wage rate on the wage determination for the work actually performed. In the event the Employment and Training Administration withdraws approval of a training program, the Contractor will no longer be permitted to utilize trainees at less than the applicable predetermined rate for the work performed until an acceptable program is approved.

(iii) Equal Employment Opportunity. The utilization of apprentices, trainees, and journeymen under this part shall be in conformity with the equal employment opportunity requirements of Executive Order 11246, as amended, and 29 CFR Part 30.

5. Compliance with Copeland Act Requirements.

The Contractor shall comply with the requirements of 29 CFR Part 3, which are incorporated by reference in this contract.

6. Subcontracts.

The Contractor or subcontractor shall insert in any subcontracts the clauses contained in 29 CFR §§ 5.5(a)(1) through (10) and such other clauses as the Federal Aviation Administration may by appropriate instructions require, and also a clause requiring the subcontractors to include these clauses in any lower tier subcontracts. The prime contractor shall be responsible for the compliance by any subcontractor or lower tier subcontractor with all the contract clauses in 29 CFR § 5.5.

7. Contract Termination: Debarment.

A breach of the contract clauses in paragraph 1 through 10 of this section may be grounds for termination of the contract, and for debarment as a contractor and a subcontractor as provided in 29 CFR § 5.12.

8. Compliance with Davis-Bacon and Related Act Requirements.

All rulings and interpretations of the Davis-Bacon and Related Acts contained in 29 CFR Parts 1, 3, and 5 are herein incorporated by reference in this contract.

9. Disputes Concerning Labor Standards.

Disputes arising out of the labor standards provisions of this contract shall not be subject to the general disputes clause of this contract. Such disputes shall be resolved in accordance with the procedures of the Department of Labor set forth in 29 CFR Parts 5, 6, and 7. Disputes within the meaning of this clause include disputes between the Contractor (or any of its subcontractors) and the contracting agency, the U.S. Department of Labor, or the employees or their representatives.

10. Certification of Eligibility.

(i) By entering into this contract, the Contractor certifies that neither it (nor he or she) nor any person or firm who has an interest in the Contractor's firm is a person or firm ineligible to be awarded Government contracts by virtue of section 3(a) of the Davis-Bacon Act or 29 CFR § 5.12(a)(1).

(ii) No part of this contract shall be subcontracted to any person or firm ineligible for award of a Government contract by virtue of section 3(a) of the Davis-Bacon Act or 29 CFR § 5.12(a)(1).

(iii) The penalty for making false statements is prescribed in the U.S. Criminal Code, 18 USC § 1001.

## CERTIFICATION OF OFFEROR/BIDDER REGARDING DEBARMENT

By submitting a bid/proposal under this solicitation, the bidder or offeror certifies that neither it nor its principals are presently debarred or suspended by any Federal department or agency from participation in this transaction.

### DISADVANTAGED BUSINESS ENTERPRISE

**Bid Information Submitted as a matter of responsiveness:**

The Owner's award of this contract is conditioned upon Bidder or Offeror satisfying the good faith effort requirements of 49 CFR § 26.53.

As a condition of responsiveness, the Bidder or Offeror must submit the following information with its proposal on the forms provided herein:

- 1) The names and addresses of Disadvantaged Business Enterprise (DBE) firms that will participate in the contract;
- 2) A description of the work that each DBE firm will perform;
- 3) The dollar amount of the participation of each DBE firm listed under (1);
- 4) Written statement from Bidder or Offeror that attests their commitment to use the DBE firm(s) listed under (1) to meet the Owner's project goal
- 5) Written confirmation from each listed DBE firm that it is participating in the contract in the kind and amount of work provided in the prime contractor's commitment; and
- 6) If Bidder or Offeror cannot meet the advertised project DBE goal, evidence of good faith efforts undertaken by the Bidder or Offeror as described in appendix A to 49 CFR part 26. The documentation of good faith efforts must include copies of each DBE and non-DBE subcontractor quote submitted to the bidder when a non-DBE subcontractor was selected over a DBE for work on the contract.

**Bid Information submitted as a matter of responsibility:**

The Owner's award of this contract is conditioned upon Bidder or Offeror satisfying the good faith effort requirements of 49 CFR § 26.53.

As a condition of responsibility, every Bidder or Offeror must submit the following information on the forms provided herein within five days after bid opening.

- 1) The names and addresses of Disadvantaged Business Enterprise (DBE) firms that will participate in the contract;
- 2) A description of the work that each DBE firm will perform;
- 3) The dollar amount of the participation of each DBE firm listed under (1);
- 4) Written statement from Bidder or Offeror that attests their commitment to use the DBE firm(s) listed under (1) to meet the Owner's project goal;
- 5) Written confirmation from each listed DBE firm that it is participating in the contract in the kind and amount of work provided in the prime contractor's commitment; and
- 6) If Bidder or Offeror cannot meet the advertised project DBE goal, evidence of good faith efforts undertaken by the Bidder or Offeror as described in appendix A to 49 CFR part 26. The documentation of good faith efforts must include copies of each DBE and non-DBE subcontractor quote submitted to the bidder when a non-DBE subcontractor was selected over a DBE for work on the contract.

**Contract Assurance (49 CFR § 26.13; mandatory text provided) –**

The Contractor, subrecipient or subcontractor shall not discriminate on the basis of race, color, national origin, or sex in the performance of this contract. The Contractor shall carry out applicable requirements of 49 CFR part 26 in the award

and administration of DOT-assisted contracts. Failure by the Contractor to carry out these requirements is a material breach of this contract, which may result in the termination of this contract or such other remedy as the recipient deems appropriate, which may include, but is not limited to:

- 1) Withholding monthly progress payments;
- 2) Assessing sanctions;
- 3) Liquidated damages; and/or
- 4) Disqualifying the Contractor from future bidding as non-responsible.

**Prompt Payment (49 CFR § 26.29; acceptable/sample text provided) –**

The prime contractor agrees to pay each subcontractor under this prime contract for satisfactory performance of its contract no later than [specify number of days, not to exceed 30] days from the receipt of each payment the prime contractor receives from [Name of recipient]. The prime contractor agrees further to return retainage payments to each subcontractor within [specify number of days, not to exceed 30] days after the subcontractor's work is satisfactorily completed. Any delay or postponement of payment from the above referenced time frame may occur only for good cause following written approval of the [Name of Recipient]. This clause applies to both DBE and non-DBE subcontractors.

**Termination of DBE Subcontracts (49 CFR § 26.53(f); acceptable/sample text provided) –**

The prime contractor must not terminate a DBE subcontractor listed in response to [include Solicitation paragraph number where paragraph 12.3.1, Solicitation Language appears] (or an approved substitute DBE firm) without prior written consent of [Name of Recipient]. This includes, but is not limited to, instances in which the prime contractor seeks to perform work originally designated for a DBE subcontractor with its own forces or those of an affiliate, a non-DBE firm, or with another DBE firm.

The prime contractor shall utilize the specific DBEs listed to perform the work and supply the materials for which each is listed unless the contractor obtains written consent [Name of Recipient]. Unless [Name of Recipient] consent is provided, the prime contractor shall not be entitled to any payment for work or material unless it is performed or supplied by the listed DBE.

[Name of Recipient] may provide such written consent only if [Name of Recipient] agrees, for reasons stated in the concurrence document, that the prime contractor has good cause to terminate the DBE firm. For purposes of this paragraph, good cause includes the circumstances listed in 49 CFR §26.53.

Before transmitting to [Name of Recipient] its request to terminate and/or substitute a DBE subcontractor, the prime contractor must give notice in writing to the DBE subcontractor, with a copy to [Name of Recipient], of its intent to request to terminate and/or substitute, and the reason for the request.

The prime contractor must give the DBE five days to respond to the prime contractor's notice and advise [Name of Recipient] and the contractor of the reasons, if any, why it objects to the proposed termination of its subcontract and why [Name of Recipient] should not approve the prime contractor's action. If required in a particular case as a matter of public necessity (e.g., safety), [Name of Recipient] may provide a response period shorter than five days.

In addition to post-award terminations, the provisions of this section apply to preaward deletions of or substitutions for DBE firms put forward by offerors in negotiated procurements.

### Federal Fair Labor Standards Act

All contracts and subcontracts that result from this solicitation incorporate by reference the provisions of 29 CFR part 201, et seq, the Federal Fair Labor Standards Act (FLSA), with the same force and effect as if given in full text. The FLSA sets minimum wage, overtime pay, recordkeeping, and child labor standards for full and part-time workers.

The [Contractor | Consultant] has full responsibility to monitor compliance to the referenced statute or regulation. The [Contractor | Consultant] must address any claims or disputes that arise from this requirement directly with the U.S. Department of Labor – Wage and Hour Division.

### TRADE RESTRICTION CERTIFICATION

By submission of an offer, the Offeror certifies that with respect to this solicitation and any resultant contract, the Offeror –

- 1) is not owned or controlled by one or more citizens of a foreign country included in the list of countries that discriminate against U.S. firms as published by the Office of the United States Trade Representative (USTR);
- 2) has not knowingly entered into any contract or subcontract for this project with a person that is a citizen or national of a foreign country included on the list of countries that discriminate against U.S. firms as published by the USTR; and
- 3) has not entered into any subcontract for any product to be used on the Federal project that is produced in a foreign country included on the list of countries that discriminate against U.S. firms published by the USTR.

This certification concerns a matter within the jurisdiction of an agency of the United States of America and the making of a false, fictitious, or fraudulent certification may render the maker subject to prosecution under Title 18 USC § 1001.

The Offeror/Contractor must provide immediate written notice to the Owner if the Offeror/Contractor learns that its certification or that of a subcontractor was erroneous when submitted or has become erroneous by reason of changed circumstances. The Contractor must require subcontractors provide immediate written notice to the Contractor if at any time it learns that its certification was erroneous by reason of changed circumstances.

Unless the restrictions of this clause are waived by the Secretary of Transportation in accordance with 49 CFR § 30.17, no contract shall be awarded to an Offeror or subcontractor:

- 1) who is owned or controlled by one or more citizens or nationals of a foreign country included on the list of countries that discriminate against U.S. firms published by the USTR; or
- 2) whose subcontractors are owned or controlled by one or more citizens or nationals of a foreign country on such USTR list; or
- 3) who incorporates in the public works project any product of a foreign country on such USTR list.

Nothing contained in the foregoing shall be construed to require establishment of a system of records in order to render, in good faith, the certification required by this provision. The knowledge and information of a contractor is not required to exceed that which is normally possessed by a prudent person in the ordinary course of business dealings.

The Offeror agrees that, if awarded a contract resulting from this solicitation, it will incorporate this provision for certification without modification in all lower tier subcontracts. The Contractor may rely on the certification of a prospective subcontractor that it is not a firm from a foreign country included on the list of countries that discriminate against U.S. firms as published by USTR, unless the Offeror has knowledge that the certification is erroneous.

This certification is a material representation of fact upon which reliance was placed when making an award. If it is later determined that the Contractor or subcontractor knowingly rendered an erroneous certification, the Federal Aviation Administration (FAA) may direct through the Owner cancellation of the contract or subcontract for default at no cost to the Owner or the FAA.

### **CERTIFICATION REGARDING LOBBYING**

The Bidder or Offeror certifies by signing and submitting this bid or proposal, to the best of his or her knowledge and belief, that:

- (1) No Federal appropriated funds have been paid or will be paid, by or on behalf of the Bidder or Offeror, to any person for influencing or attempting to influence an officer or employee of an agency, a Member of Congress, an officer or employee of Congress, or an employee of a Member of Congress in connection with the awarding of any Federal contract, the making of any Federal grant, the making of any Federal loan, the entering into of any cooperative agreement, and the extension, continuation, renewal, amendment, or modification of any Federal contract, grant, loan, or cooperative agreement.
- (2) If any funds other than Federal appropriated funds have been paid or will be paid to any person for influencing or attempting to influence an officer or employee of any agency, a Member of Congress, an officer or employee of Congress, or an employee of a Member of Congress in connection with this Federal contract, grant, loan, or cooperative agreement, the undersigned shall complete and submit Standard Form-LLL, "Disclosure Form to Report Lobbying," in accordance with its instructions.
- (3) The undersigned shall require that the language of this certification be included in the award documents for all sub-awards at all tiers (including subcontracts, subgrants, and contracts under grants, loans, and cooperative agreements) and that all sub-recipients shall certify and disclose accordingly.

This certification is a material representation of fact upon which reliance was placed when this transaction was made or entered into. Submission of this certification is a prerequisite for making or entering into this transaction imposed by section 1352, title 31, U.S. Code. Any person who fails to file the required certification shall be subject to a civil penalty of not less than \$10,000 and not more than \$100,000 for each such failure.

### **PROCUREMENT OF RECOVERED MATERIALS**

Contractor and subcontractor agree to comply with Section 6002 of the Solid Waste Disposal Act, as amended by the Resource Conservation and Recovery Act, and the regulatory provisions of 40 CFR Part 247. In the performance of this contract and to the extent practicable, the Contractor and subcontractors are to use products containing the highest percentage of recovered materials for items designated by the Environmental Protection Agency (EPA) under 40 CFR Part 247 whenever:

- 1) The contract requires procurement of \$10,000 or more of a designated item during the fiscal year; or
- 2) The contractor has procured \$10,000 or more of a designated item using Federal funding during the previous fiscal year.

The list of EPA-designated items is available at [www.epa.gov/smm/comprehensive-procurement-guidelines-construction-products](http://www.epa.gov/smm/comprehensive-procurement-guidelines-construction-products).

Section 6002(c) establishes exceptions to the preference for recovery of EPA-designated products if the contractor can demonstrate the item is:

- a) Not reasonably available within a timeframe providing for compliance with the contract performance schedule;
- b) Fails to meet reasonable contract performance requirements; or
- c) Is only available at an unreasonable price.

## EXHIBITS

Exhibit A – 2023 PCI

See next page

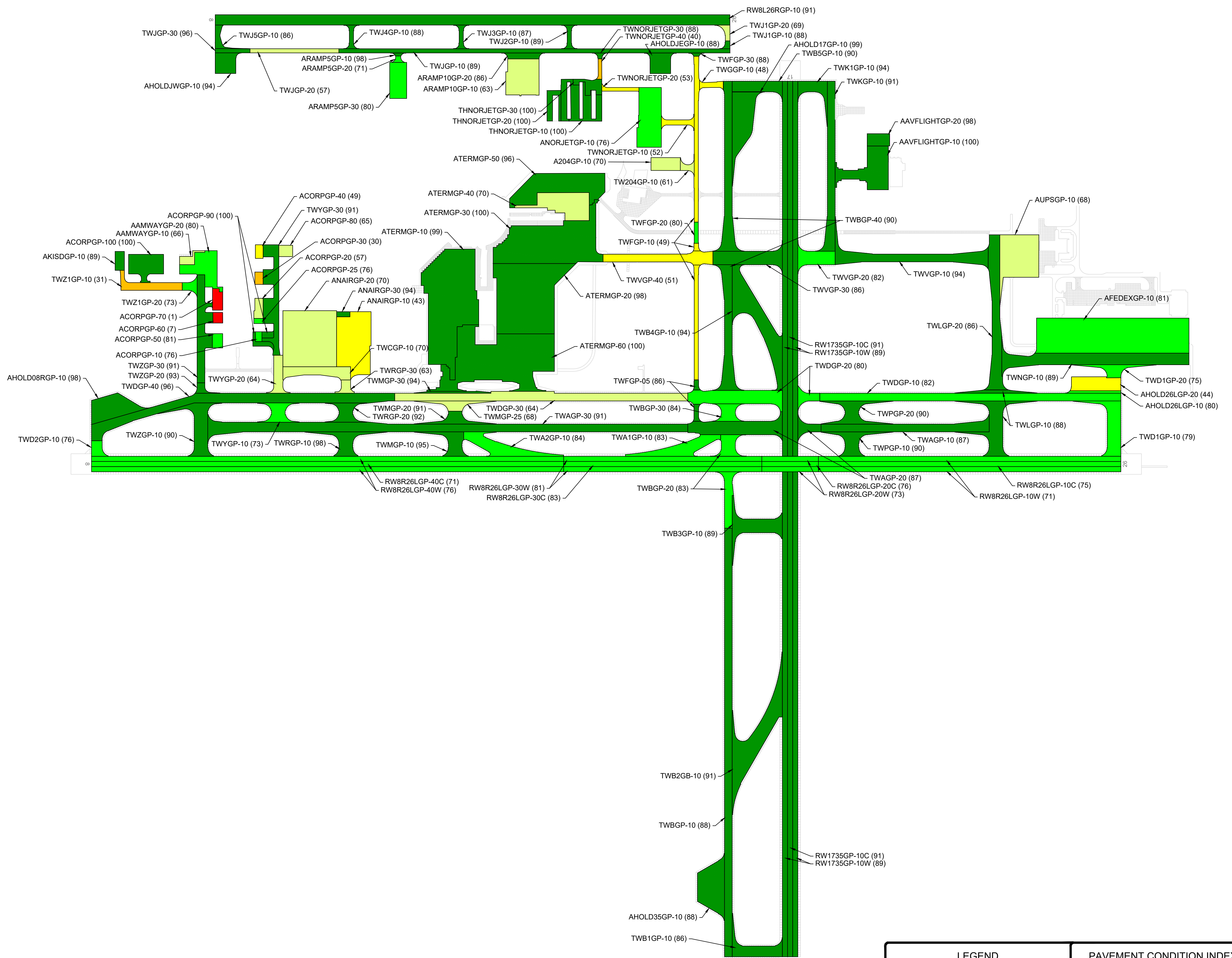

**LEGEND**

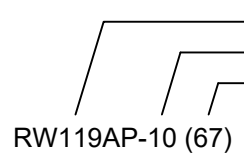
 BRANCH IDENTIFIER  
SECTION IDENTIFIER  
PCI VALUE

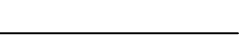
 SECTION BREAK LINE

**PAVEMENT CONDITION INDEX REPAIR**

100		PREVENTIVE MAINTENANCE
85		MAJOR REHABILITATION
70		RECONSTRUCTION
55		
40		
25		
10		
0		

**applied pavement TECHNOLOGY** 115 W. Main Street, Suite 400  
Urbana, IL 61801  
Tel: (217) 398-3977  
Fax: (217) 398-4027

AGENCY: Michigan Department of Transportation  
Office of Aeronautics

LOCATION: Gerald R. Ford International Airport  
Grand Rapids, MI

PAGE TITLE: 2023 PAVEMENT CONDITION MAP

PROJECT DATE: OCT. 2022	CREATION DATE: SEP. 2023	PROJECT MANAGER: KMP	JOB NUMBER: 2022-001-AM01
DRAWING SCALE: 1"=300'	LAST MODIFIED DATE: SEP. 2023	REVISED BY: KEW	DRAWN BY: MDK
FILENAME: Grand Rapids.dwg	LAYOUT NAME/NUMBER: PCI	FIGURE: 6	

## Exhibit B – GRR ASR Locations

See next page



## Exhibit C – Pavement Section Locations with PCRs

See next page

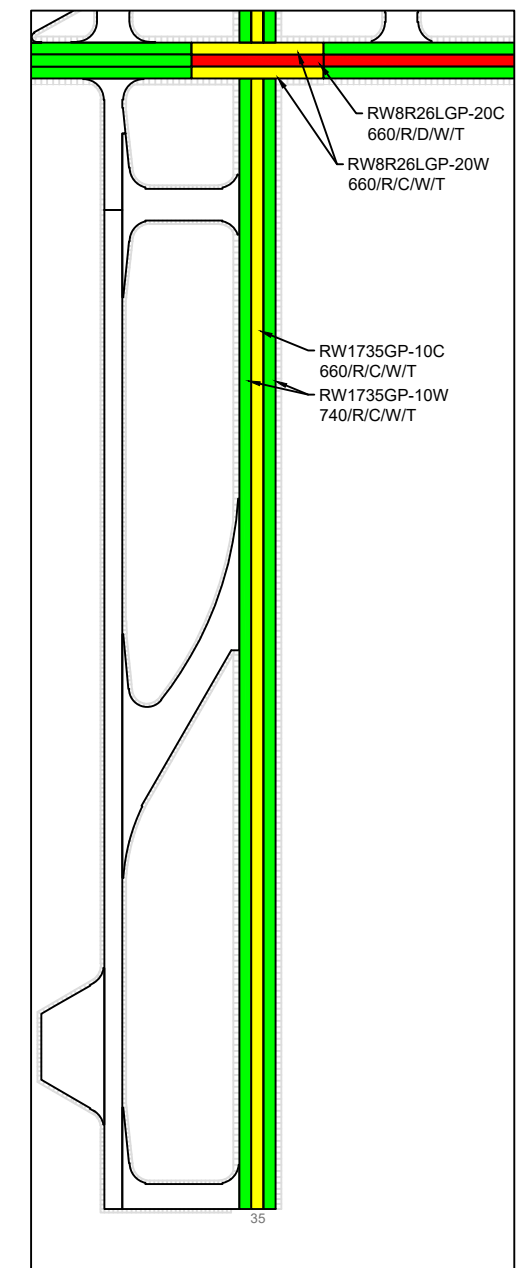
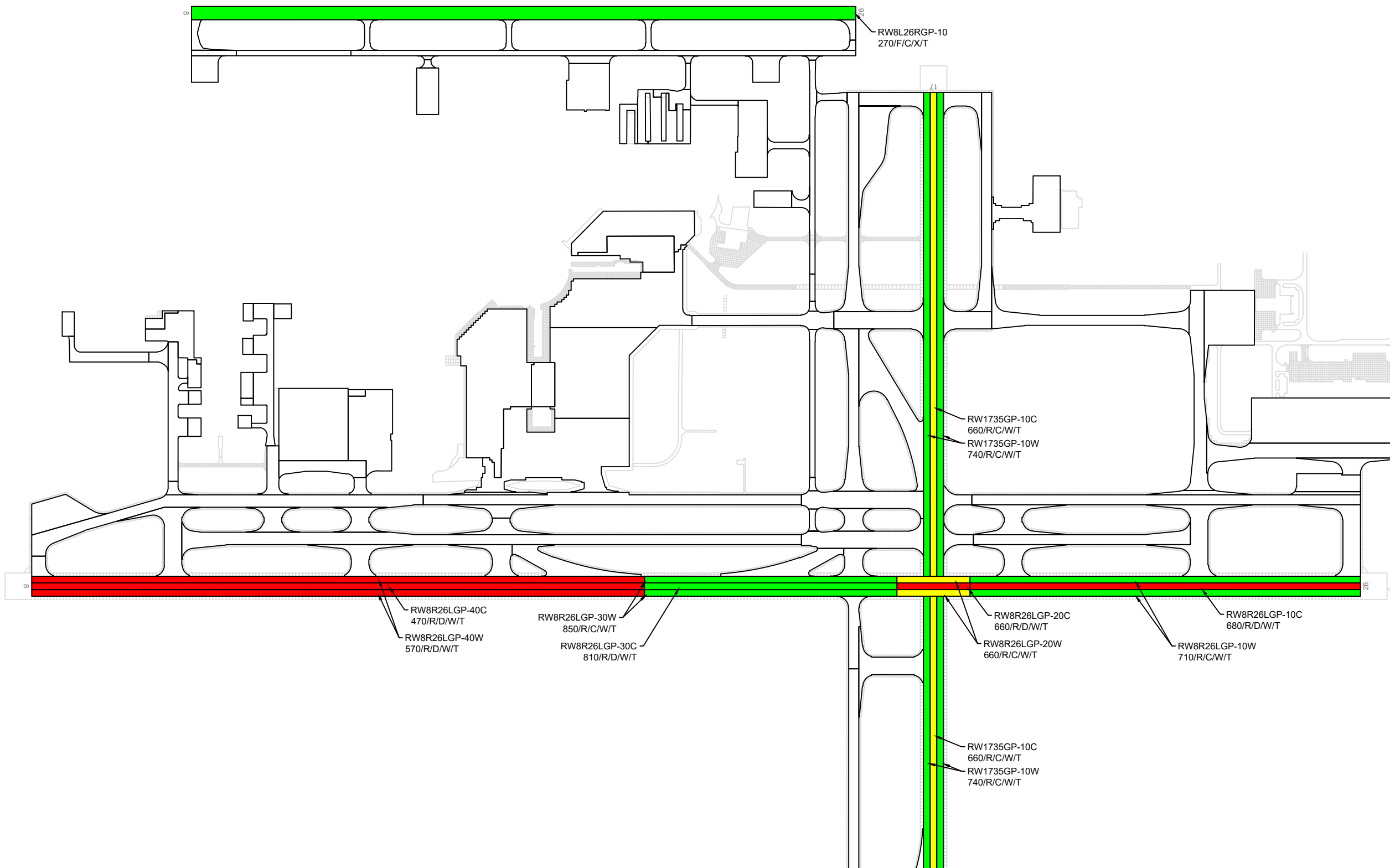

**LEGEND**

BRANCH IDENTIFIER  
SECTION IDENTIFIER  
PCR VALUE  
 SECTION BREAK LINE

**LEGEND**

STRUCTURALLY ADEQUATE  
 RESTRICTIONS MAY APPLY  
 STRUCTURALLY INADEQUATE  
 NOT EVALUATED

**applied pavement TECHNOLOGY** 115 W. Main Street, Suite 400  
Urbana, IL 61801  
Tel: (217) 398-3977  
Fax: (217) 398-4027

AGENCY: Michigan Department of Transportation  
Office of Aeronautics

LOCATION: Gerald R. Ford International Airport  
Grand Rapids, MI

PAGE TITLE: PCR Assessment Map

PROJECT DATE: FEB. 2020	CREATION DATE: JUN. 2020	PROJECT MANAGER: KMP	JOB NUMBER: 2020-098-AM01
DRAWING SCALE: 1" = 900'	LAST MODIFIED DATE: JAN. 2023	REVISED BY: KEW	DRAWN BY: KEW
FILENAME: Grand Rapids.dwg	LAYOUT NAME/NUMBER: PCR	FIGURE NUMBER: A-1	

## CHAPTER 5. FWD TESTING AND ANALYSIS

### Background

Visual surveys provide critical data for network-level decision-making and level of serviceability, but they do not provide a direct analysis of the structural integrity or load-carrying capacity of the pavements. To evaluate these properties, a nondestructive testing program was conducted using APTEch's Dynatest heavy-weight model Falling Weight Deflectometer (FWD). A network-level FWD testing plan and associated analysis was conducted following guidance in FAA Advisory Circulars 150/5370-11B, *Use of Nondestructive Testing in the Evaluation of Airport Pavements*, and 150/5320-6G, *Airport Pavement Design and Evaluation*.

Deflection testing data are used to backcalculate in situ material properties, to calculate pavement responses to load, and as inputs to other pavement analyses and designs. Deflection testing provides inputs for the structural analysis of the pavement sections without costly and time-consuming material testing required of destructive testing and analyses. Deflection testing was performed on Runways 8R-32L, 8L-32R, and 17-35 in June 2021.

### Layer Thicknesses

Pavement layer thicknesses, material types, and strengths are critical inputs when determining the structural capacity of pavement. The pavement layer types and thicknesses used in Pavement Classification Rating (PCR) analysis were determined from historical records provided by GRR. The pavement layer thicknesses from records are summarized in table 5-1.

Table 5-1. Pavement layer thicknesses.

Branch	Section	Const. Date	Surface Thickness, in	Surface Material <sup>1</sup>	Base Thickness, in	Base Material <sup>1</sup>	Subbase Thickness, in	Subbase Material <sup>1</sup>
RW8R26LGP	10C	11/4/2002	14.00	PCC	10.00	CTB	18.00	ABC <sup>2</sup>
	10W	11/4/2002	14.00	PCC	10.00	CTB	18.00	ABC <sup>2</sup>
	20C	3/4/1998	14.00	PCC	10.00	CTB	18.00	ABC <sup>2</sup>
	20W	3/4/1998	14.00	PCC	10.00	CTB	18.00	ABC <sup>2</sup>
	30C	12/4/1998	14.00	PCC	10.00	CTB	18.00	ABC <sup>2</sup>
	30W	12/4/1998	14.00	PCC	10.00	CTB	18.00	ABC <sup>2</sup>
	40C	11/4/2002	14.00	PCC	10.00	CTB	18.00	ABC <sup>2</sup>
RW1735GP	10C	3/4/1998	14.00	PCC	10.00	CTB	18.00	ABC <sup>2</sup>
	10W	3/4/1998	14.00	PCC	10.00	CTB	18.00	ABC <sup>2</sup>
RW8L26RGP	10	6/3/2015	4.00	AC	8.00	CABC	30.00	ABC

<sup>1</sup> AC = asphalt concrete (flexible), P-401; PCC = portland cement concrete (rigid), P-501; CTB = cement treated base, P-304; CABC = crushed aggregate base course, P-209; ABC = aggregate base course, P-154.

<sup>2</sup> Where indicated (in rigid pavements), aggregate base layer is not directly used in structural analysis as it is accounted for in the backcalculated k-value from FWD data analysis

## FWD Description and Testing Configuration

The FWD is a load impulse testing device capable of simulating in magnitude and duration the dynamic loads applied to a pavement by aircraft and vehicular wheel loads. A dynamic load is applied by dropping a set of masses onto a circular load plate, as illustrated in figure 5-1. A range of load magnitudes is achieved by varying the number of masses used and the heights from which they are dropped. The actual load magnitude is measured using a load cell within the load plate, and the resulting deflections are measured by transducers located at the center of the load plate and at preset distances away from the load plate.

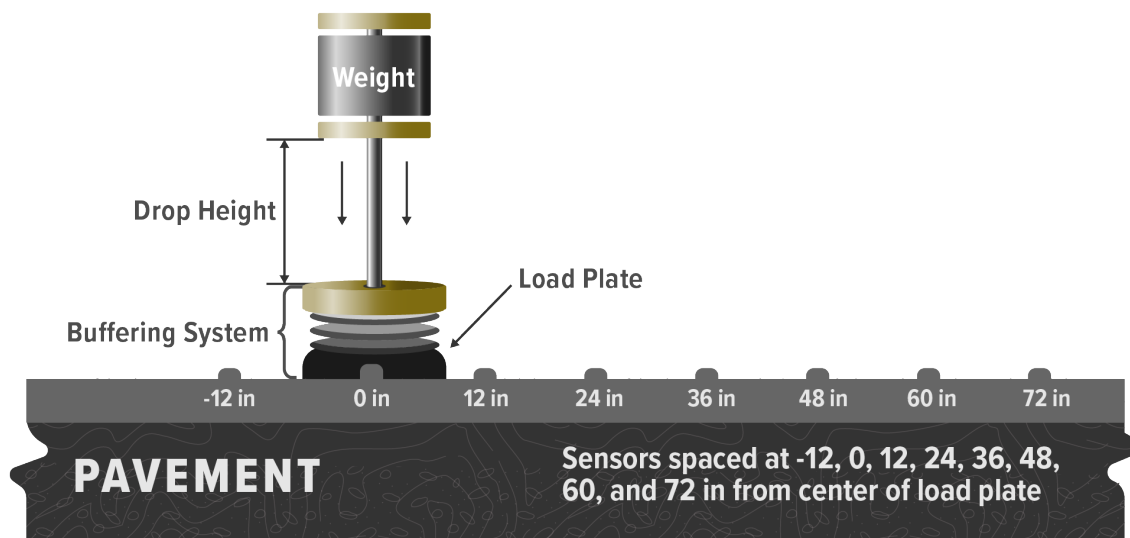

Figure 5-1. FWD testing concept and sensor configuration.

For testing, the FWD equipment is configured to address local conditions. The purpose of the customized configuration is to simulate the actual loading conditions in the field. GRR has heavy commercial aircraft traffic as well as light general aviation aircraft traffic, resulting in a wide range of wheel loads. Therefore, the following FWD configuration was used to simulate loadings from a range of aircraft:

- Three-drop test sequence with loads ranging from 20,000 to 45,000 lbs.
- Large load plate with an 8.85-inch radius.
- Sensors spaced at 0, 12, 24, 36, 48, 60, and 72 inches.

A meaningful characterization of pavement properties requires the collection of sufficient data. Test lanes were distributed across the facilities to ensure an adequate number of locations per pavement section, with four test lanes on each runway. The lanes nearest the centerline were tested at 100-foot intervals, with tests spaced at 200-foot intervals in outer test lanes. For PCC pavements, test lane offsets from the centerline vary based on slab dimensions to obtain mid-slab data. Test lanes for each facility are as follows:

- Runway 8R-26L: 17.5-foot and 37.5-foot offsets, left and right of centerline.
- Runway 17-35: 12.5-foot and 37.5-foot offsets, left and right of centerline.

- Runway 8L-26R: 8.0-feet and 25.0-feet offsets, left and right of centerline.

## Analysis Method

The analysis method varies depending on the pavement type (i.e., rigid or flexible). The subgrade and layer moduli are considered field values and require correction to laboratory or design values. The AC layer modulus is also adjusted to a standard temperature (90 °F) for FAA design.

PCC pavements are analyzed using the AREA method, which is based on rigid plate theory. The results of the AREA analysis are elastic moduli for the bound upper layers (PCC and stabilized base layers) and modulus of subgrade support (k-value). The elastic modulus of the bound layers is split into the moduli of the two layers (the PCC layer and underlying stabilized base) through an assumed modulus ratio ( $E_1/E_2$ ) that considers the material types, ages, and conditions. The bonding condition between stabilized layers is also assessed during analysis. In this analysis, a modulus ratio of 4 was used for the PCC/CTB relative strengths.

The elastic modulus of the PCC layer is then equated to a flexural strength using the correlation shown in equation 1 (taken from FAA Advisory Circular 150/5370-11B), as this is a direct input for PCR calculation:

$$M_r = 43.5 * \left( \frac{E_{pcc}}{10^6} \right) + 488.5 \quad (\text{Eq. 1})$$

where:

$M_r$  = PCC modulus of rupture (or flexural strength), psi.

$E_{pcc}$  = Backcalculated PCC elastic modulus, Mpsi.

Because of the significant difference in layer stiffness between PCC pavement and unbound subbase layers, the k-values determined from FWD testing account for the structural contribution of aggregate layers. In other words, it represents the k-value of the combined aggregate and subgrade layers. Likewise, because FWD testing captures in-place conditions, strength gained from subgrade stabilization is reflected in the subgrade strengths backcalculated from FWD test data for both rigid and flexible pavements. The determined k-value represents a dynamic value and is multiplied by 0.5 to obtain a design (or static) value.

For flexible pavements, deflection testing data are analyzed using a layered elastic analysis approach. BAKFAA software was used for this project. The results of layered elastic backcalculation are elastic moduli for each pavement layer and for the subgrade.

Because the FAA does not recommend a specific flexible pavement subgrade correction factor, recommendations presented in the *Guide for Mechanistic-Empirical Design of New and Rehabilitated Pavement Structures* developed by the American Association of State Highway and Transportation Officials (AASHTO) are used to obtain a design value. For flexible pavements, a correction factor of 0.35 is used where a granular base layer is present.

Finally, the subgrade modulus is equated to a California Bearing Ratio (CBR) using FAA guidance, as shown in equation 2 (FAA Advisory Circulars 150/5370-11B and 150/5320-6G):

$$E_{subgrade} = 1,500 \times CBR \quad (\text{Eq. 2})$$

where:

$E_{subgrade}$  = Elastic Modulus of Subgrade, psi.  
 $CBR$  = California Bearing Ratio, percent.

CBR is a standard measure of strength for unbound materials and refers to the material's resistance to load compared to a standard reference material. In FAARFIELD, the user is allowed to input either CBR or modulus values for flexible pavement.

## Testing Results

Analysis of the deflection testing results consists of assessing normalized deflections and determining subgrade support and pavement layer moduli. The pavement sections correspond to the sections defined for the PCI surveys and are identified on the map included in Appendix A.

### Normalized Deflections

Normalized deflections are used to analyze the overall load/deflection response of the pavement. The measured deflections are normalized to a 46,000-lb (46.0-kip) load to simulate a typical heavy wheel load at GRR. Because the FWD directly simulates the loading of an aircraft, it is not necessary to introduce factors to correlate the pavement response to the typical wheel load. The normalized deflection profile can be used to assess changes in subgrade support, variations within a pavement section, and the relative structural condition of a pavement.

The average and coefficient of variation (COV) of the normalized deflections are summarized in table 5-2. Deflections are reported in thousands of an inch, or mils. While the average normalized deflections generally vary between pavement sections due to differences in pavement cross sections, areas with comparatively high deflections or high COVs (typically greater than 25 percent) can indicate variability in layer thicknesses or strengths, variability in subgrade support, or deterioration within the pavement structure, either globally or locally. Normalized deflection plots are presented in figures 5-2 through 5-4.

Runway 8R-26L section 40C (keel) has high deflections compared to the rest of the pavement sections on this runway, indicating it is the weakest section. In general, the keel sections of Runway 8R-26L are weaker than their adjacent outer sections, with several sections having average normalized deflections 25 to 30 percent higher compared to the outer sections. Many sections also have high COVs indicating significant variation for these individual sections.

Runway 17-35 keel section has also slightly higher deflections in the keel section compared to the outer pavement section. There is also significant variability in the deflections along this runway, with increased variability at the north end, as illustrated in figure 5-3.

Table 5-2. Summary of FWD analysis results.

Branch	Section	46.0-kip Normalized Deflection, mils		Modulus, Mpsi			PCC Flexural Strength, psi	Static k-value, psi/in	CBR, %
		Avg.	COV	AC	PCC	CTB			
RW8R26LGP	10C	12.6	38%	-	3.824	0.478	655	104	-
	10W	8.0	29%	-	4.965	0.621	704	162	-
	20C	12.9	31%	-	3.799	0.475	654	86	-
	20W	9.5	50%	-	4.197	0.525	671	162	-
	30C	10.0	33%	-	5.839	0.730	743	90	-
	30W	6.5	23%	-	7.043	0.880	795	161	-
	40C	19.9	17%	-	2.433	0.304	594	48	-
	40W	13.1	28%	-	2.569	0.321	600	109	-
RW1735GP	10C	10.2	37%	-	4.146	0.518	669	118	-
	10W	8.2	27%	-	5.176	0.647	714	139	-
RW8L26RGP	10	56.6	17%	0.229	-	-	-	-	7.4

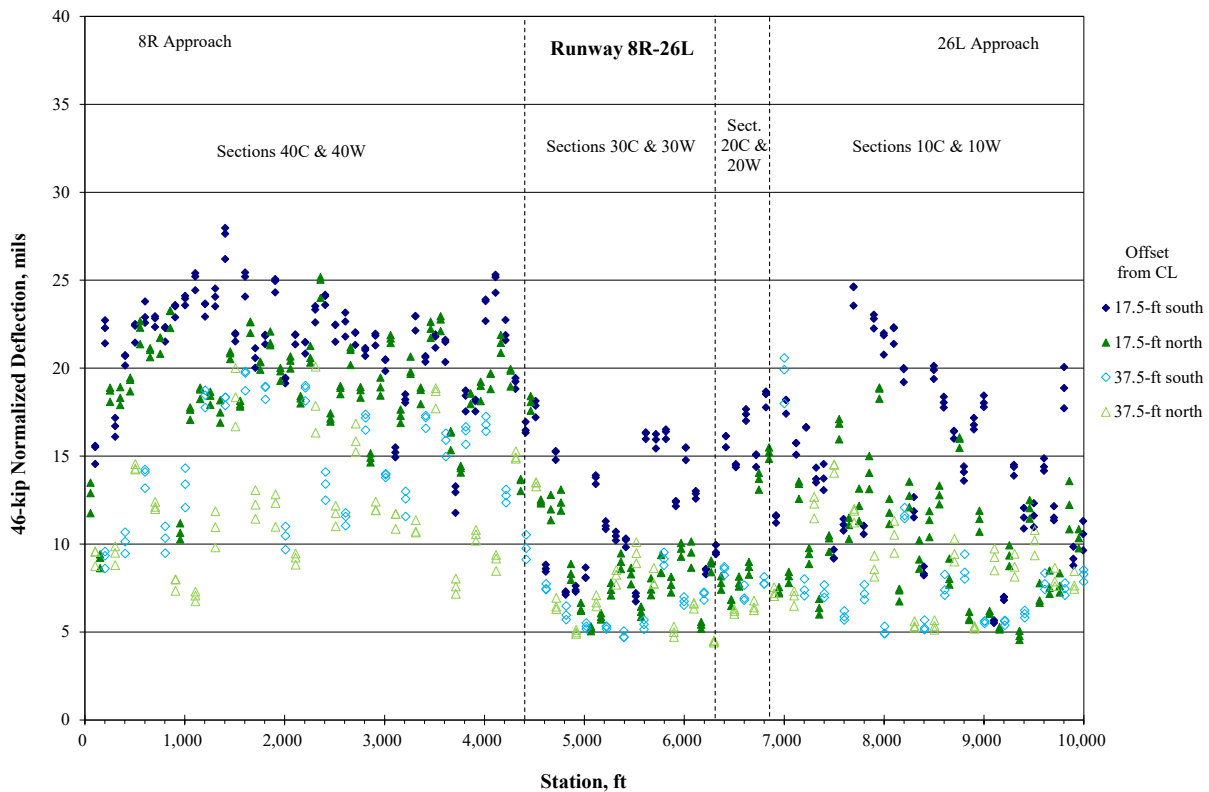

Figure 5-2. Runway 8R-26L normalized deflection profile plot.

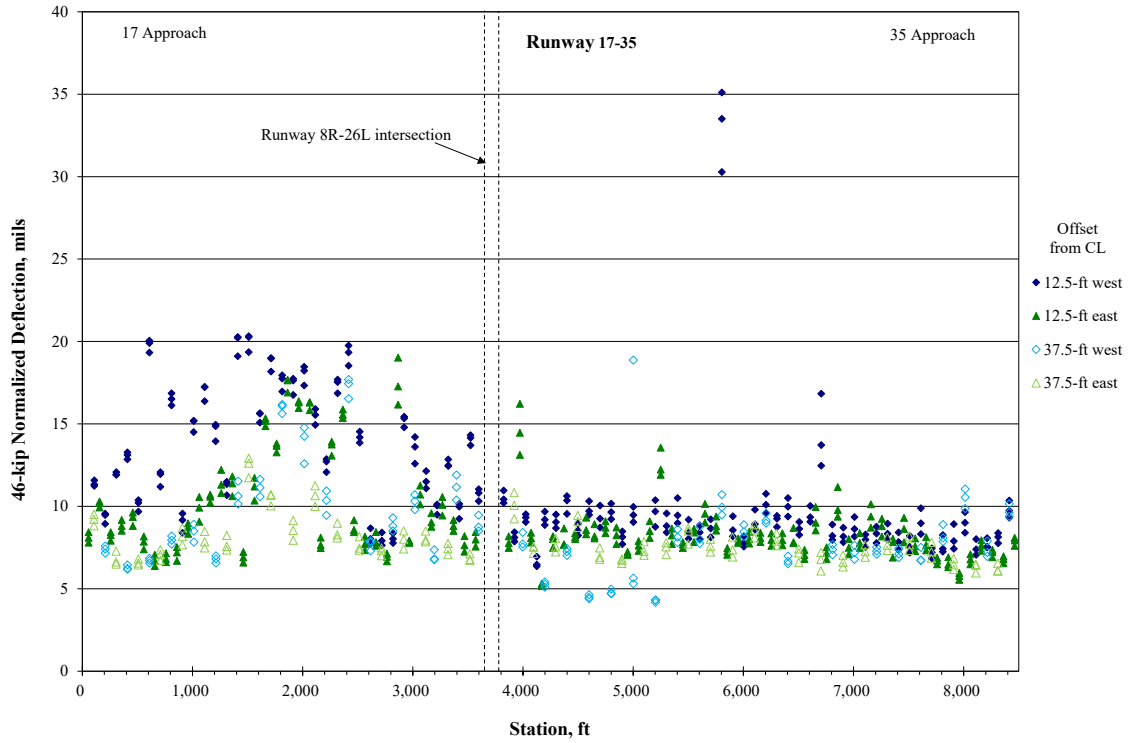

Figure 5-3. Runway 17-35 normalized deflection profile plot.

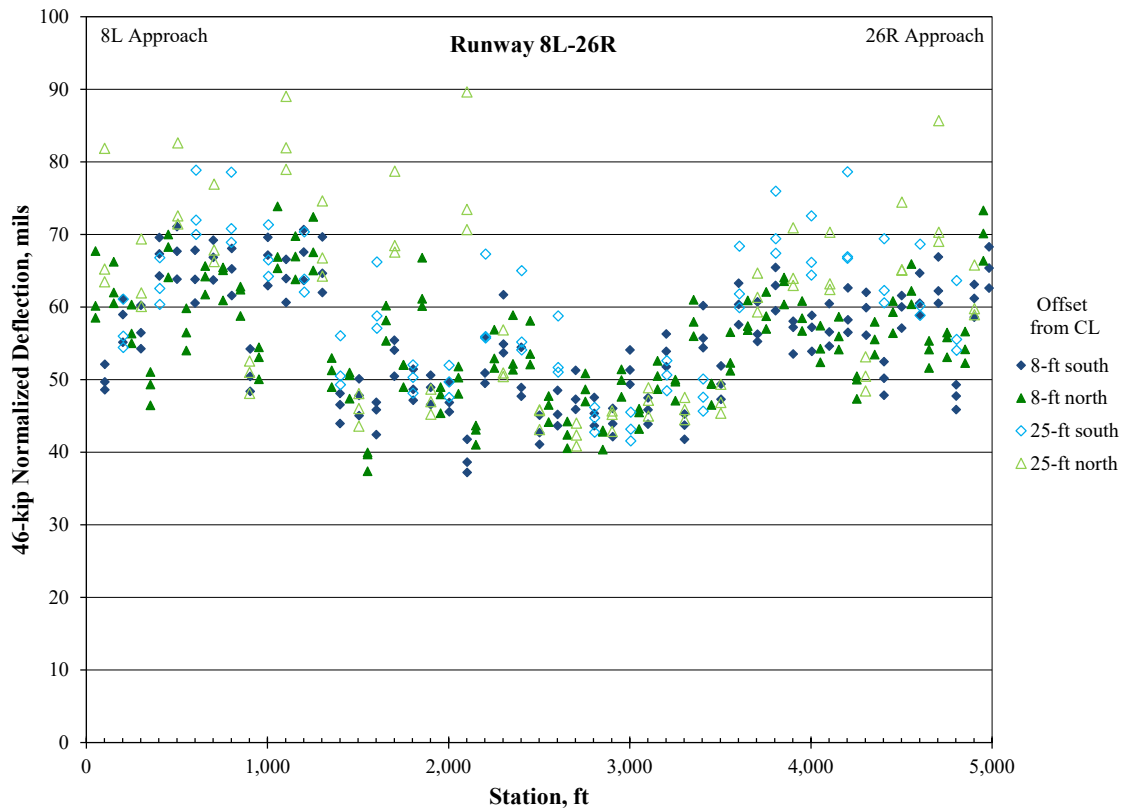

Figure 5-4. Runway 8L-26R normalized deflection profile plot.

Runway 8L-26R is comprised of one section (keel and outer areas are not distinguished because the runway width is only 100 ft while the width of the other runways is 150 ft). Statistically, there is less variability in deflections on this runway compared to the others; however, variation can be seen in figure 5-4.

### Subgrade Support

As previously stated, backcalculated k-values for rigid pavements were determined using plate theory (AREA method), while the subgrade modulus for the flexible pavements was backcalculated using layered elastic analysis software (BAKFAA). The backcalculated values are considered field values and are adjusted for use in design as previously discussed. The subgrade support conditions listed in table 5-2 are reported as either a CBR for flexible pavements or a k-value for rigid pavements and have already been adjusted to reflect static/design values. As previously stated, the k-values determined from analysis of FWD data also reflect the structural contribution of aggregate base/subbase layers.

The average static k-values for Runway 8R-26L range from 48 to 162 psi/in, as presented in table 5-2. These values correspond to modulus values ranging from 2,900 to 13,800 psi. (FAARFIELD allows the user to enter either the k-value or modulus of the subgrade.) The highest values are encountered in the outer pavement sections of the runway with section 40C (keel) having the lowest value.

Similarly, Runway 17-35 keel section 10C has slightly lower k-value of 118 psi/in (modulus of approximately 9,200 psi) compared to the outer section with a k-value of 139 psi/in (modulus of approximately 11,400 psi), although there is less of a difference between the keel and outer pavement sections than observed on Runway 8R-26L.

The average CBR of Runway 8L-26R is 7.4 percent, which equates to a modulus of 11,100 psi.

These subgrade strengths correspond to low subgrade strength categories, as discussed in the chapter that follows. The backcalculated subgrade strengths reflect in-place strengths of silty clay present at this airport.

### Pavement Layer Properties

The PCC modulus calculated during backcalculation analysis is correlated to a flexural strength for direct input in FAARFIELD. PCC flexural strengths between 650 and 800 psi are typical for sound PCC pavement. As presented in table 5-2, the majority of results are within this range, but few sections have a lower value. Runway 8R-26L sections 40C and 40W have the lowest values with flexural strengths of 594 and 600 psi, respectively. The rest of the sections on Runway 8R-26L and Runway 17-35 have flexural strengths above 650 psi, although generally only slightly above this value. While PCIs in 2020 for the runway pavements were not unusually low, particularly for their age, some load-related distress and other distress types were identified including ASR. This distress was recorded on Runway 8R-26L sections 20C and 20W where visual indicators of the distress were observed. While not confirmed in this location through laboratory testing, it should also be noted that ASR has been confirmed in select PCC taxiways and apron pavements at the airport.

The typical moduli for sound cement-treated base (CTB) layers range from 500,000 to 1,000,000 psi. The results fall into this range except for Runway 8R-26L sections 40C and 40W, which have a CTB moduli around 305,000 psi and sections 10C and 20C that have moduli around 480,000 psi. The remainder of the backcalculated CTB moduli values vary between 520,000 and 880,000 psi. FAARFIELD assumes a modulus of 500,000 psi for CTB, which was used as a conservative value during PCR analysis for each section, with the exception of sections RW8R26LGP-40C, -40W, -10C, and -20C. For these sections, the CTB modulus determined from FWD data analysis was lower than the FAARFIELD default value, so the actual backcalculated CTB modulus was used and entered as a variable rigid stabilized base layer.

The backcalculated AC moduli are determined for the temperature at the time of testing. Because asphalt is a temperature-dependent material, the moduli are adjusted to a standard design temperature (90 °F for FAA design of the surface layer). Table 5-2 presents the temperature-corrected average elastic modulus obtained for the surface layer for Runway 8L-26R. A higher modulus often indicates the material has hardened due to aging (oxidation) of the asphalt. A conservative default value of 200,000 psi was used for the modulus input in FAARFIELD.

## **Summary**

APTech performed nondestructive testing using its FWD in June of 2021. The data collected during that testing were used to assess the normalized deflections, to determine the subgrade support conditions (CBR for flexible pavement and k-value for rigid pavements), and to determine the pavement layer moduli and PCC flexural strength. These results were in turn used to determine inputs for the structural analyses, in particular the development of PCRs, which are presented in the following chapter.

## CHAPTER 6. PCR DETERMINATION

### Background

The Federal Aviation Administration (FAA) recently updated pavement strength reporting guidance to align with International Civil Aviation Organization (ICAO) guidance, with reporting requirements transitioning to Pavement Classification Ratings (PCRs) instead of PCNs.

The primary inputs required to complete the PCR calculations align with those used for determining PCNs and include the pavement cross section, subgrade strength, and aircraft traffic details. The inputs used in the PCN assessment for GRR are assumed to be unchanged and were applied to the new PCR process and calculations. Original sources of the analysis inputs were available from design documents provided by GRR. The aircraft traffic is based on Traffic Flow Management System Counts (TFMSC) Report for 2019 with distribution for individual runways provided by airport personnel.

This document presents an overview of the Aircraft Classification Rating (ACR)–PCR system, analysis inputs, along with the PCR results. APTech performed this work in accordance with guidance outlined in Federal Aviation Association (FAA) Advisory Circular 150/5335-5D, *Standardized Method for Reporting Pavement Strength – PCR*, and corresponding FAARFIELD 2.0 software.

A map identifying the analyzed pavement areas with corresponding branch and section names is shown in Appendix A. This map also illustrates the results of the PCR assessment.

### ACR–PCR Overview

The ACR–PCR system of reporting pavement strength was developed by ICAO. Since the United States is a member of this organization, the FAA is obligated to adhere to this system and provides guidance to comply with ICAO standards. There is no direct correlation between PCNs and PCRs or ACNs and ACRs; however, the updated “ratings” are roughly a factor of ten higher than their “number” counterpart, with ACR calculations being based on hundreds of kilograms for a derived single wheel load rather than thousands of kilograms. ACRs and PCRs are rounded to the nearest tens.

The ACR–PCR procedure is structured so that a pavement with a given PCR can support an aircraft that has an ACR equal to or less than the PCR. Likewise, the pavement cannot, according to the procedure, handle frequent loadings from an aircraft with an ACR exceeding the PCR. Infrequent overloads may be acceptable in accordance with the general overload guidance, which is presented within this report. As with the ACN-PCN system, aircraft operators are required to obtain permission to use a facility when their aircraft’s ACR exceeds the published PCR.

### ACR

According to FAA Advisory Circular 150/5335-5D, ACR is defined as a number that expresses the relative effect of an aircraft at a given weight on a pavement structure for a specified standard subgrade strength. The ACR can be calculated for any operating weight. Higher ACRs indicates an aircraft has a more severe effect on the pavement, while lower values indicate a less severe effect.

ACRs are reported by pavement type (i.e., rigid or flexible) and subgrade strength category (i.e., A, B, C, or D, as defined later). Pavements with a concrete layer are generally considered rigid, including those with an asphalt overlay. Stronger subgrade support conditions (e.g., granular subgrade soils with higher elastic modulus values [E]) correspond to lower ACRs as compared to weaker subgrade support conditions. The ACR has a minimum value of 0 and no upper limit.

ACRs are presented for the analyzed aircraft listed in table 6-2 (presented with the aircraft traffic data), as determined using FAA's FAARFIELD software, for rigid and flexible pavements and the applicable subgrade strength category. The presented ACRs are for the specified aircraft weights. For a given aircraft, the ACRs will decrease as aircraft weight decreases. It is also worth noting that tire pressure influences ACRs. For example, given two aircraft with similar weights and gear configurations (for a specific pavement type and subgrade strength category), the aircraft with the lower tire pressure will have a lower ACR, indicating that its demand on a pavement is less than a similar aircraft with a higher tire pressure.

### PCR

The PCR is assigned to a pavement and expresses the relative load carrying capacity of that pavement in terms of allowable load for unrestricted operations based on aircraft departures (frequency and weight) and pavement layer properties. The determined PCR is specific for the given conditions and should be recalculated if the aircraft types or volumes change significantly. As with the ACR, the PCR has a minimum value of 0 and has no upper limit. In addition to the numerical value, the PCR is reported with four codes, which represent the following categories:

- Pavement Type
  - R = Rigid
  - F = Flexible
- Subgrade Strength Category
  - A = High ( $E \geq 21,756$  psi)
  - B = Medium ( $14,504 \text{ psi} \leq E < 21,756$  psi)
  - C = Low ( $8,702 \text{ psi} \leq E < 14,504$ )
  - D = Ultra Low ( $E \leq 8,702$  psi)
- Maximum Allowable Tire Pressure
  - W = Unlimited (no pressure limit)
  - X = High (pressure limited to 254 psi)
  - Y = Medium (pressure limited to 181 psi)
  - Z = Low (pressure limited to 73 psi)
- Pavement Evaluation Method
  - T = Technical Evaluation
  - U = Using Aircraft Evaluation

Note that the subgrade strength category is now based on the elastic modulus of the subgrade (rather than CBR and top-of-base k-value, as it was in the ACN-PCN system) and is now consistent for both flexible and rigid pavement types.

## General Overload Guidance

For aircraft with an ACR that exceeds the recommended PCR, ICAO overload guidance can be referenced. While pavement overloads are expected to decrease pavement life, they do not typically cause immediate or catastrophic failures unless they are extremely excessive. Alternatively, the indicated aircraft may be able to safely use these facilities (following the ACR/PCR procedure) by operating at a reduced weight. If aircraft do not operate at their analyzed weights, then the PCR should be recalculated using the actual aircraft weights.

In general, aircraft with ACRs in excess of 10 percent of the reported PCR should be restricted to avoid potential damage to the pavement (note that this percentage increased from 5 to 10 percent for rigid pavement compared to previous PCN guidance; it is unchanged for flexible pavement). Exceeding this recommendation may result in a reduced pavement life. Appendix C of FAA Advisory Circular 150/5335-5D presents the following guidance for pavement overloads (based on ICAO guidance):

- For flexible or rigid pavements, occasional traffic by aircraft with an ACR not exceeding 10 percent above the reported PCR should not adversely affect the pavement.
- The annual number of overload traffic operations should not exceed approximately 5 percent of the total annual aircraft traffic.
- Overloads should not normally be permitted on pavements already exhibiting signs of structural distress, during periods of thaw following frost penetration, or when the strength of the pavement or its subgrade could be weakened by water.
- When overload operations are conducted, the airport owner should regularly inspect the pavement condition. Periodically the airport owner should review the criteria for overload operations. Excessive repetition of overloads can cause a significant reduction in pavement life or accelerate when a pavement will require major rehabilitation.

In general, pavement overloads are expected to decrease pavement life but do not often cause immediate or catastrophic failures unless they are excessive.

## **PCR Analysis Inputs**

Traffic, pavement (thickness and material type), and subgrade data are used directly in FAARFIELD to calculate PCRs. For rigid pavements, the concrete flexural strength is also a direct input. Using these inputs, in simplified terms, FAARFIELD determines the critical aircraft within a traffic mix, adjusts the annual departures of the critical aircraft to achieve a Cumulative Damage Factor (CDF) equal to the maximum CDF of the aircraft mix, determines the maximum allowable gross weight of the critical aircraft to achieve a CDF of 1.0, computes the ACR of the critical aircraft at that maximum allowable weight, iterates these steps for other aircraft in the mix, and presents the maximum ACR from this process as the PCR. The PCR should be associated with a “regularly-using” aircraft to represent the pavement section. The FAA recommends 250 annual departures be considered the threshold for regular use, with engineering judgement required for seasonal or occasional use aircraft. Engineering judgement is also required to avoid overreporting pavement strength.

## Aircraft Traffic

The characterization of traffic is an important part of the structural analysis of airport pavement facilities, with inputs specifically including aircraft types, annual departure volumes, and weights. FAA pavement evaluation and design procedures generally use only departure data for the analysis because they have heavier loads due to fuel weight. The analyzed aircraft traffic mix for GRR is obtained from TFMSR Report for 2019. APTECH compiled a representative traffic mix for use in the PCR analysis including the distribution for individual runways provided by airport personnel. This information is presented in table 6-1. Table 6-2 provides the ACRs for these aircraft for rigid and flexible pavements corresponding to the applicable subgrade strength category.

Because PCR calculations are dependent on the aircraft using a facility, PCRs should be recalculated if the aircraft types, weights, or volumes change significantly. Additionally, inaccurate traffic can cause the PCR to be overestimated or underestimated.

## Pavement and Subgrade Layer Inputs

The FAA's FAARFIELD software uses Layered Elastic Analysis (LEA) for modeling pavement structures for determining ACR and PCR. LEA is used for both flexible and rigid pavements as outlined in FAA Advisory Circular 150/5335-5D, which is a change from previous ACN-PCN modeling. The updated analysis better aligns with the FAA's current approach for airfield pavement design. For rigid pavements, a top-of-base k-value is no longer considered; the actual subgrade strength and individual base layers are input for PCR analysis, which is a departure from how PCNs were analyzed using a top-of-base k-value reflecting strength contribution of all underlying layers, including stabilized bases. Because FWD testing was performed to assess the pavement layers, the strength contribution of aggregate layers is already incorporated in the analyzed k-values for the rigid pavements. The updated procedure uses uniform standard subgrade categories for both flexible and rigid pavement, which is based on the elastic modulus of the subgrade.

In FAARFIELD, the user enters pavement layer material and thickness and can vary elastic modulus for certain materials if needed to more accurately reflect current support conditions. For rigid pavements, the concrete flexural strength is a direct input for the PCR analysis. Since testing was done to determine material strengths, the calculated flexural strength was used in this analysis. Default FAARFIELD layer moduli were used during analysis to represent the strength of other pavement layers, providing conservative inputs. The only exception is the CTB layer for sections RW8R26LGP-40C, -40W, -10C, and -20C, where the layer was modeled in FAARFIELD as a variable rigid stabilized base layer (since the modulus of CTB layers cannot be adjusted) using the backcalculated modulus, which is slightly lower than FAARFIELD's default CTB modulus. The subgrade elastic modulus values were correlated from backcalculated k-values or CBRs, as previously described.

Table 6-1. Traffic data for runways at GRR.

Aircraft	Weight, lbs.	Gear Config. <sup>1</sup>	Annual Departures		
			Runway 8R-26L	Runway 17-35	Runway 8L-26R
Cessna Skylane 182	3,110	S	155	155	310
Cessna 310	5,200	S	98	98	196
Cessna Chancellor 414	6,579	S	112	112	224
Cessna 208 Caravan	8,750	S	352	352	704
Beech King Air 90	9,650	S	18	18	35
Cessna Citation II/Bravo	15,100	S	210	210	420
Cessna Citation CJ4	17,968	S	248	248	495
F/A 18 Hornet	51,900	S	1	1	2
Beech Super King Air 350	15,100	D	136	136	273
Learjet 75	21,500	D	443	443	886
BAe HS 125/700-800/Hawker 800	27,520	D	127	127	108
Bombardier Challenger 300	38,850	D	686	686	588
Embraer ERJ-145	45,500	D	887	887	760
Bombardier CRJ-200	53,131	D	1,776	1,184	0
Bombardier CRJ-700	75,000	D	1,576	1,051	0
Bombardier CRJ-900	90,900	D	4,561	3,041	0
Boeing 717-200	122,000	D	373	249	0
Airbus A319	141,978	D	794	529	0
Airbus A320 All Series	150,796	D	1,638	1,092	0
Boeing 737-700	155,000	D	1,108	739	0
Boeing (Douglas) MD 88	161,000	D	735	490	0
Boeing 737-800	174,700	D	621	414	0
Boeing 737-900	188,200	D	818	545	0
Airbus A321 All Series	197,094	D	165	110	0
Boeing 757-200	256,000	2D	94	63	0
Airbus A310 All Series	315,041	2D	56	37	0
Boeing KC-135 Stratotanker	322,500	2D	4	2	0
Airbus A300 B5-600	365,747	2D	471	314	0
Boeing Globemaster 3	585,000	2T	5	3	0

<sup>1</sup> Configuration of the main gear: S = single wheel, D = dual wheel, 2D = dual tandem, and 2T = triple tandem, as defined in FAA Order 5300.7, *Standard Naming Convention for Aircraft Landing Gear Configurations*.

Table 6-2. ACRs for analyzed aircraft.

Aircraft	Weight, lbs	Gear Config.	ACRs for Rigid Pavement for Subgrade Category		ACRs for Flexible Pavement, Subgrade Category C
			Subgrade Category C	Subgrade Category D	
Cessna Skylane 182	3,110	S	10	10	10
Cessna 310	5,200	S	10	10	20
Cessna Chancellor 414	6,579	S	20	20	20
Cessna 208 Caravan	8,750	S	20	30	30
Beech King Air 90	9,650	S	20	20	30
Cessna Citation II/Bravo	15,100	S	60	60	60
Cessna Citation CJ4	17,968	S	70	70	70
F/A 18 Hornet	51,900	S	200	200	210
Beech Super King Air 350	15,100	D	40	40	30
Learjet 75	21,500	D	60	70	60
BAe HS 125/700-800/Hawker 800	27,520	D	80	80	70
Bombardier Challenger 300	38,850	D	130	130	110
Embraer ERJ-145	45,500	D	140	150	140
Bombardier CRJ-200	53,131	D	170	180	160 <sup>1</sup>
Bombardier CRJ-700	75,000	D	260	270	260 <sup>1</sup>
Bombardier CRJ-900	90,900	D	310	320	300 <sup>1</sup>
Boeing 717-200	122,000	D	380	390	330 <sup>1</sup>
Airbus A319	141,978	D	400	410	330 <sup>1</sup>
Airbus A320 All Series	150,796	D	430	450	360 <sup>1</sup>
Boeing 737-700	155,000	D	460	470	380 <sup>1</sup>
Boeing (Douglas) MD 88	161,000	D	530	540	460 <sup>1</sup>
Boeing 737-800	174,700	D	540	560	450 <sup>1</sup>
Boeing 737-900	188,200	D	600	620	500 <sup>1</sup>
Airbus A321 All Series	197,094	D	620	640	520 <sup>1</sup>
Boeing 757-200	256,000	2D	420	470	340 <sup>1</sup>
Airbus A310 All Series	315,041	2D	520	590	430 <sup>1</sup>
Boeing KC-135 Stratotanker	322,500	2D	540	610	450 <sup>1</sup>
Airbus A300 B5-600	365,747	2D	670	740	550 <sup>1</sup>
Boeing Globemaster 3	585,000	2T	660	770	550 <sup>1</sup>

<sup>1</sup> Provided for reference; aircraft not included for Runway 8L-26R flexible pavement analysis.

## PCR Results

The resulting PCRs based on the analyses performed using FAARFIELD are summarized in table 6-3. These results are also depicted in the figure included in Appendix #. The corresponding maximum allowable weights for applicable gear types are also presented. These weight correlations were determined using FAARFIELD and guidance in FAA Advisory Circular 150/5335-5D, which provides approximations based on general correlations but are not specific to the analyzed aircraft.

Table 6-3. Summary of PCR results.

Branch	Section	PCR <sup>1</sup>	Maximum Allowable Weight, lbs., by Gear Configuration		
			S	D	2D
RW8R26LGP	10C	680/R/D/W/T	120,000	206,000	314,000
	10W	710/R/C/W/T	120,000	219,000	353,000
	20C	660/R/D/W/T	120,000	200,000	306,000
	20W	660/R/C/W/T	120,000	206,000	332,000
	30C	810/R/D/W/T	120,000	240,000	366,000
	30W	850/R/C/W/T	120,000	250,000	418,000
	40C	470/R/D/W/T	117,000	148,000	226,000
	40W	570/R/D/W/T	120,000	175,000	268,000
RW1735GP	10C	660/R/C/W/T	120,000	206,000	332,000
	10W	740/R/C/W/T	120,000	227,000	366,000
RW8L26RGP	10 <sup>2</sup>	270/F/C/X/T	70,000	100,000	165,000

<sup>1</sup>The following shading indicates the relative capacity of the pavement for the corresponding analyzed traffic (listed in table 6-1, with ACRs presented in table 6-2):

Structurally adequate
Restrictions may apply
Structurally inadequate

<sup>2</sup>To avoid reporting PCRs that are excessively greater than the ACNs of the aircraft in the analyzed traffic mix, PCR does not exceed the ACR of the most demanding aircraft by more than 25 percent (per Advisory Circular 150/5335-5D recommendations).

Generally, a single PCR is published for each runway, and the structural capacity is often limited by the weakest area of that entire runway (as traffic, especially for heavier aircraft, often require use of the entire length of the facility). As such, recommendations are provided herein for the values to publish for each runway.

Runway 8R-26L was determined to have a PCR of 470/R/D/W/T based on the results of section 40C, which is the lowest PCR for this runway. This value is based on the Airbus A300 as the critical aircraft. The ACRs of the Boeing Globemaster 3, Airbus A300, Airbus A321, Airbus A310, Boeing 737-800, Boeing 737-900, Boeing KC-135 Stratotanker, and Boeing (Douglas) MD 88 aircraft at maximum take-off weights greatly exceed the PCR for the section 40C as well as a few other sections of this runway. Most of these aircraft operate on a frequent basis at GRR. Based on the PCR results, to avoid overloading, GRR should consider limiting weights or

operations of the listed aircraft on this runway, possibly shifting some operations to Runway 17-35 when possible, or accept the risk of a reduced service life or deterioration that may result. It should be noted that load-related distress, in the form of LTD cracking, was present in each section during the most recent PCI inspection, further indicating a structural deficiency. These pavements should be monitored for future deterioration.

Runway 17-35 was determined to have a PCR of 660/R/C/W/T based on the results of section 10C, representing the keel (loaded) area of this runway. The keel also has a lower PCR than the outer portion of the runway. The PCR is based on the Airbus A300 as the critical aircraft. The ACR of Airbus A300 aircraft is within 10 percent of the PCR, so it falls within the overload guidance. However, it does not meet the overload guidance for infrequent operations, as it operates regularly and should not be considered infrequent use. Based on this result, to avoid overloading, GRR should consider limiting weight or operations of aircraft that overload this runway or accept the risk of reduced service life or deterioration that may result. Similar to Runway 8R-26L, load-related distress in the form of LTD cracking was present during the most recent PCI inspection. This pavement should be monitored for future deterioration.

Runway 8L-26R has sufficient structural capacity for the analyzed traffic. APTech recommends reporting a PCR of 270/F/C/X/T. It should be noted that the pavement capacity of this runway exceeds the demand of the current traffic. As suggested in Advisory Circular 150/5335-5D, APTech took precautions to avoid reporting PCRs that are excessively greater than the ACRs of the aircraft in the analyzed traffic mix by limiting the result based on ACRs of the traffic using the facility. This runway may be able to support heavier aircraft, but specific aircraft would have to be analyzed in the traffic mix to verify.

In general, aircraft with ACRs greater than the PCRs for the analyzed facilities may be able to safely use these pavements, following the ACR-PCR procedure, by operating at a reduced weight. Some infrequent overloads are allowed in accordance with the general overload guidance, which is presented within this report. Aircraft operators are required to obtain permission to use a runway when their aircraft's ACR exceeds the published PCR. These operators are often aware of their aircraft's ACR for their intended operating weight.

Additionally, pavement overloads are expected to decrease pavement life but do not often cause immediate or catastrophic failures unless they are excessive. While the FAA's pavement structural capacity approach is conservative, where overload operations are conducted, decision-makers should be aware of the effect and risks of operating these aircraft based on the PCR analysis results.

## **Summary**

GRR selected APTech to update their APMS for their airport. In addition to the typical APMS services, the project included the determination of PCRs for all runway pavements (Runways 8R-32L, 8L-32R, and 17-35). Following the release of FAA Advisory Circular 150/5335-5D, a PCR assessment was authorized, which is the focus of this chapter. The assessment included reviewing available pavement construction records, conducting nondestructive testing using an FWD to assess in situ material properties, reviewing provided aircraft traffic data, and subsequently analyzing these data to determine the pavement's structural capacity.

An overview of the ACR-PCR system, inputs used for PCR calculations (including pavement layer thicknesses, material types, subgrade modulus, concrete flexural strength, and traffic), and PCR results are documented in this report. The PCRs presented within this document are calculated using the FAA's technical evaluation method for determining PCRs, as described in FAA Advisory Circular 150/5335-5D, and corresponding FAARFIELD software.

The PCR recommended for publication for Runway 8R-26L is 470/R/D/W/T. For Runway 17-35, the PCR recommended for publication is 660/R/C/W/T. The results indicate overloading of these runways by the analyzed aircraft. The PCR recommended for publication for Runway 8L-26R is 270/F/C/X/T. The analysis indicates this runway is structurally adequate for the analyzed aircraft. A map illustrating the pavement section locations and PCR results is provided in Figure 6-1.

Insert PCR Map

Figure 6-1. Pavement section locations with PCRs.